

COMPONENTS LOCATED NEAR FRONT OF VEHICLE

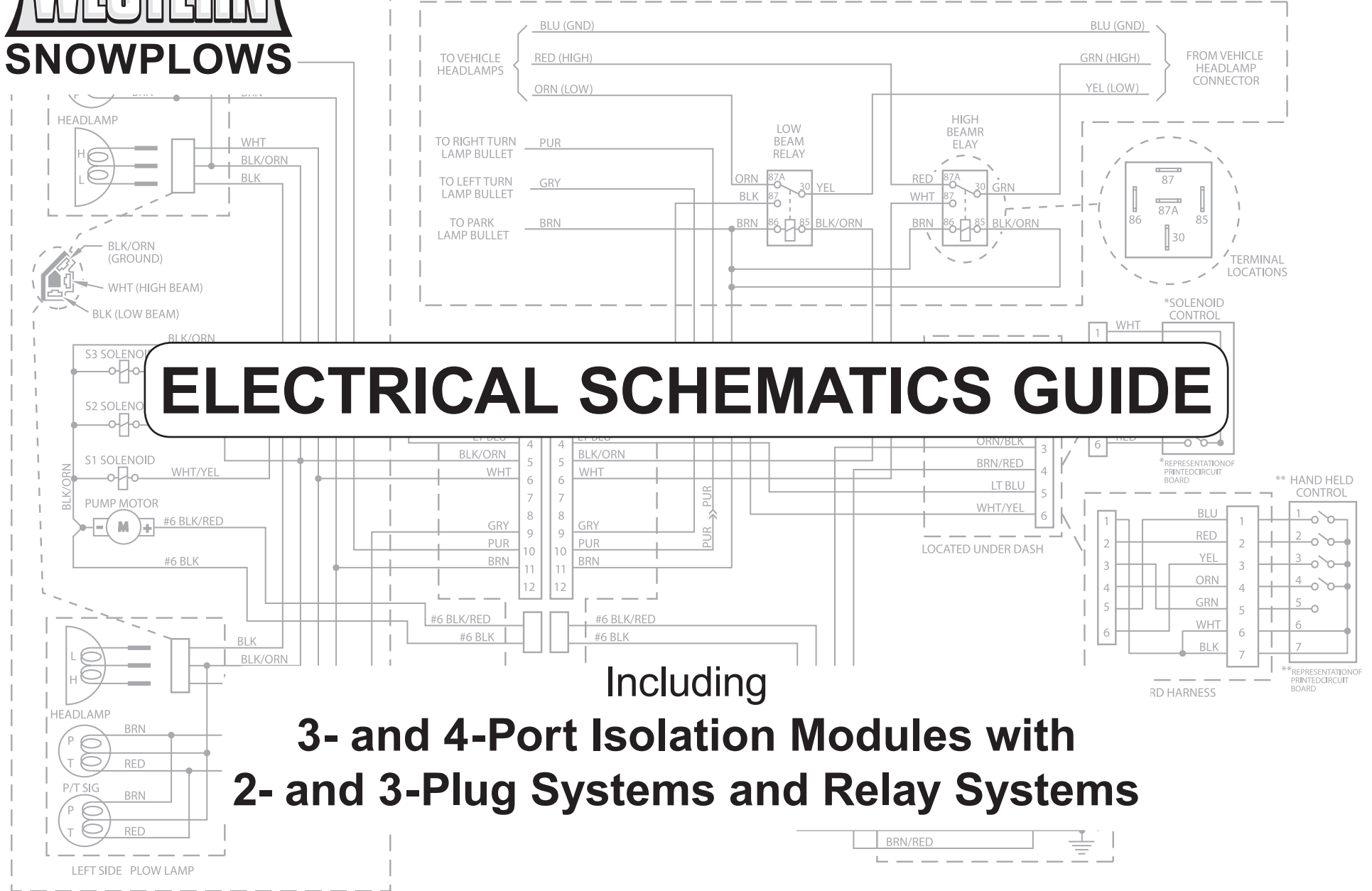

TABLE OF CONTENTS

Preface	4	4-Port Isolation Module Systems	28
Lamp Types and Harness Connectors	5	Headlamp Index	28
Electrical Connectors – 3-Plug Systems	6	Theory of Operation – Overview	29
Electrical Connectors – 2-Plug Systems	7	4-Port Isolation Module System	30
In-Line Adapter Instructions – 28027-2	8	4-Port Isolation Module System – Adapter Kits	31
Vehicle Harness with Relay – 29861	9	Configuration Plug Instructions – 26421	32
3-Port Isolation Module Systems	10	Electrical Schematic – 3-Plug Straight Blade Snowplows (3-Pin)	33
Headlamp Index	10	Electrical Schematic – 3-Plug MVP Snowplows (7-Pin)	34
Theory of Operation – Overview	11	Electrical Schematic – 2-Plug MVP PLUS Snowplows (11-Pin)	35
Theory of Operation – White Label Non-DRL Module	12	Electrical Schematic – 2-Plug WIDE-OUT Snowplows (11-Pin)	36
Theory of Operation – Green Label DRL Module	13	Headlamp Wiring	37
Theory of Operation – Blue Label DRL Module	14	Relay System	47
Electrical Schematic – 3-Plug Straight Blade Snowplows (11-Pin)	15	Relay System – Headlamp Index	47
Electrical Schematic – 3-Plug MVP® Snowplows	16	Relay System – Electrical Connectors	49
Electrical Schematic – 3-Plug Straight Blade Snowplows with Central Hydraulics	17	7-Pin Harness	50
Electrical Schematic – 2-Plug MVP PLUS™ Snowplows (11-Pin)	18	Electrical Schematic – 9-Pin Vehicle Harness – Revision 10 and Later	53
Electrical Schematic – 2-Plug WIDE-OUT™ Snowplows (11-Pin)	19	Electrical Schematic – 9-Pin Vehicle Harness – Revision 1–9	54
Headlamp Wiring	20	9-Pin Harness	55
		Electrical Schematic – 12-Pin Vehicle Harness – Revision 8 and Later	71
		Electrical Schematic – 12-Pin Vehicle Harness – Revision 1–7	72
		12-Pin Harness	73
		MVP Electrical Schematic	87
		MVP Electrical Schematic – For 2003 GM and Dodge	88
		Wiring Diagram – 61185 Park or Turn Harness Kit	89
		Electrical Legend and Wire Colors	90

PREFACE

INTRODUCTION

The purpose of this book is to provide the trained mechanic with a comprehensive reference to assist in diagnosis and repair of WESTERN® snowplow electrical systems. It contains schematics, diagrams and charts which supply information for the various types of vehicle and plow headlamp systems. Although intended primarily as a diagnostic tool for headlamp systems, the hydraulic system circuitry is also included to show the complete electrical system.

HOW TO USE THIS BOOK

Use the information in the Headlamp Index to locate the electrical schematic for the vehicle. All headlamp harnesses are tagged with the harness part number. The schematic is an abstract drawing showing the purpose of each component in the system. Where possible, component locations are indicated by enclosures on the schematic. The Lamp Type, Wire Color and Connector Identification charts and diagrams will give specific wire colors, their function and locations in connectors. Any special notes are found in the upper right corner of the schematic. Further information and a specific troubleshooting guide may be found in the appropriate Mechanic's Guides.

The 9- and 12-pin Vehicle Side schematics (relay system) contain all vehicle headlamp and harness types. The 7-pin Vehicle Side Schematics show only a few representatives applications. For other 7-pin vehicle headlamp and harness types, refer to the corresponding 9-pin Vehicle Side schematic and use only the headlamp circuitry.

EARLY REVISION VEHICLE HARNESSSES (RELAY SYSTEM)

All 9- and 12-pin vehicle harnesses are labeled with a white tag indicating the harness part number and revision level. Early 9-pin harness revisions 1–9 and 12-pin harness revisions 1–7 have a ground circuit in which the control, motor relay, and headlamp relays all ground through the 9- or 12-pin connector. Some of these early revision harnesses also have a diode in the ground wire to the headlamp relays. Complete 9- and 12-pin system schematics showing this early revision ground configuration are included in the relay section of the book. These schematics are for early revision harnesses using **only** the solenoid control. If a handheld control has been installed, the ground circuit has been modified into the later revision configuration, in which only the headlamp relays ground through the 9- or 12-pin connector and the control and motor relay ground separately to the battery. Early revision harnesses may be easily identified by a single black/orange wire on one of the motor relay primary terminals which does not continue on to the negative battery terminal. All vehicle side schematics in this book show only the later revision circuitry.

FOUNDATIONS AND COMMONS

Notice that "ground" on the harness connectors may be referred to as "common". Most domestic vehicles use a **high side drive** headlamp system in which power is supplied by the switch to either headlamp. The headlamps have a common connection to ground. Some import vehicles as well as 1999 to 2002 Chevrolet/GMC, Dodge use a **low side drive** headlamp system in which power is supplied to the common connection of the headlamps. Ground is supplied to either headlamp by the switch.

Whether the terminal in the headlamp harness is actually a negative ground or a positive 12-volt common depends on what type of vehicle headlamp system it is installed into. Prior to the publication of this book, all Western Products electrical schematics showed "ground" whether or not it was a true ground or a 12-volt common. Some of these early schematics appear in this book. Newer schematics of low side drive systems will show the more accurate term "common" where appropriate.

LAMP TYPES AND HARNESS CONNECTORS

NOTE: The lamp type is usually embossed in the headlamp lens.

NOTE: Blue ground wires may be LT or DK BLU, w/ or w/o WHT stripe, depending on harness.

Headlamp Type	Bulb Type	Headlamp Type	Bulb Type
LF	H4703	H13	9008
UF	H4701	HB-1	9004
1A1	H4851	HB-2	9003
2A1	H4652 (GMC/Chevy)	HB-3	9005
2A1	H4656 (Mitsubishi)	HB-4	9006
2B1	H6054	HB-5	9007
2D1	H6024	H11	H11
2E1	H6545		

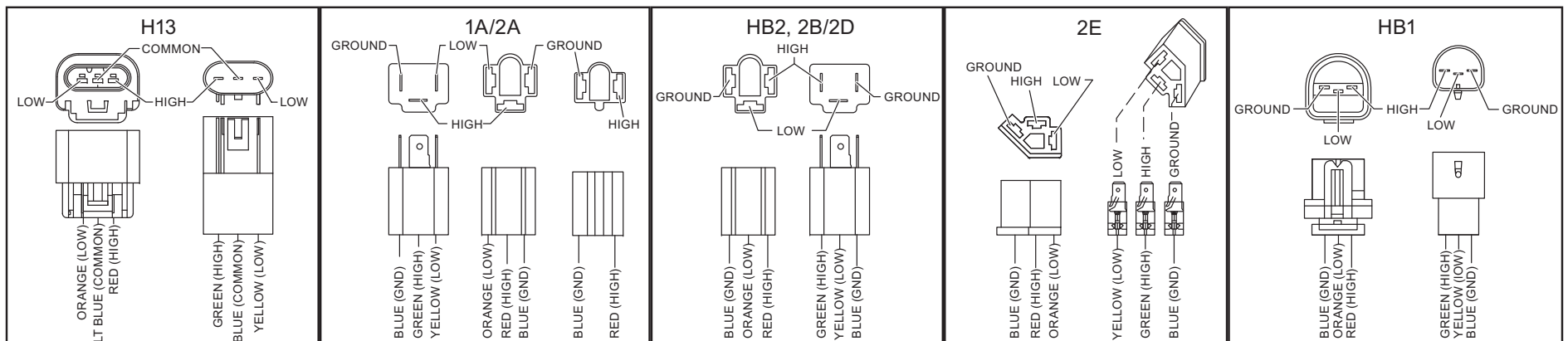
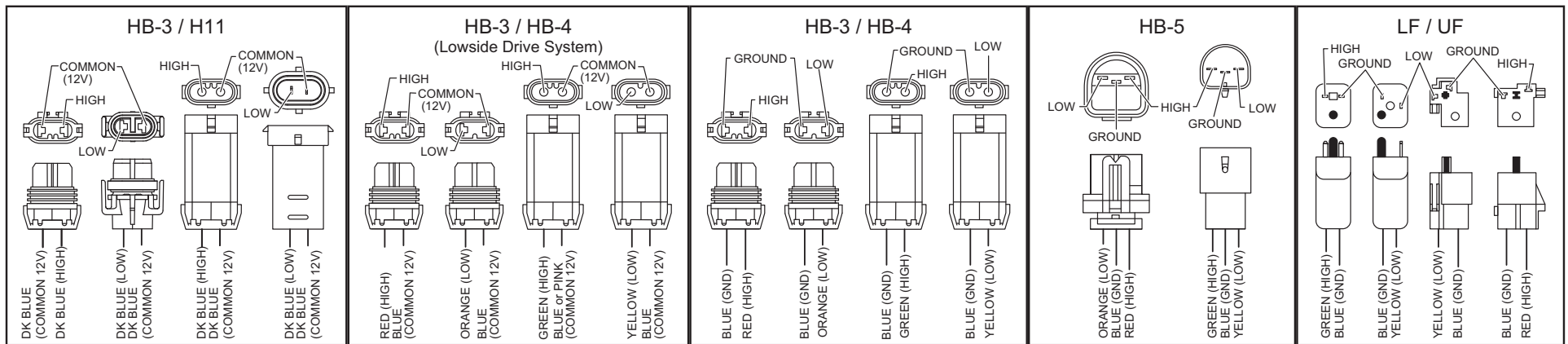

4-PORT & 3-PORT ISOLATION MODULE – ELECTRICAL CONNECTORS – 3-PLUG SYSTEMS

Solenoid Control Connectors

Control Side
(end view)

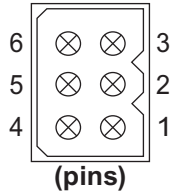

Pin No.	Solenoid Control Wire Color Only
1	White
2	Green
3	Brown
4	Black
5	Blue
6	Red

Vehicle Side
(end view)

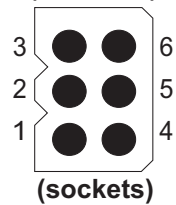

Pin No.	Wire Color	Control Function
1	Red/Yellow	+12V
2	Light Green	Valve S2
3	Orange/Black	Ground
4	Brown/Red	Motor Relay
5	Light Blue	Valve S3
6	White/Yellow	Valve S1

MVP® Blade Control Connectors

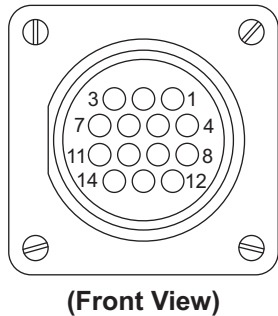

Pin No.	Wire Color
1	Light Blue w/Orange Stripe
2	Blue w/Orange Stripe
3	Black w/White Stripe
4	Light Green
5	Light Blue
6	White w/Yellow Stripe
7	Brown w/Red Stripe
8	Red w/Yellow Stripe
9	Orange w/Black Stripe
10	Brown w/Green Stripe

MVP Blade to Straight Blade Adapter Kit PN 66760K

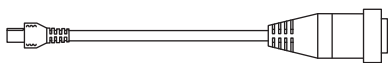

Plow Control Harnesses

Plow (End View)

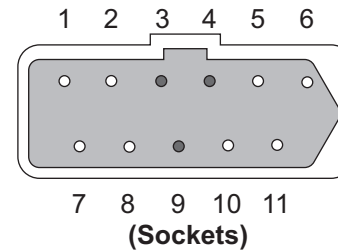

3-Pin		
Pin No.	Wire Color	Control Function
1	—	—
2	—	—
3	Light Blue	Valve S3
4	Light Green	Valve S2
5	—	—
6	—	—
7	—	—
8	—	—
9	White/Yellow	Valve S1
10	—	—
11	—	—

Plow (End View)

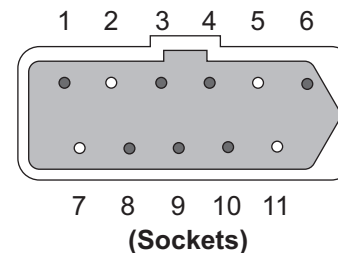

7-Pin		
Pin No.	Wire Color	Control Function
1	Black/White	Valve S4
2	—	—
3	Light Blue	Valve S2
4	Light Green	Valve S3
5	—	—
6	Red	+12V
7	—	—
8	Blue/Orange	Valve S5
9	White/Yellow	Valve S1
10	Lt Blue/Orange	Valve S6
11	—	—

Plow Lighting Harness

Plow (End View)

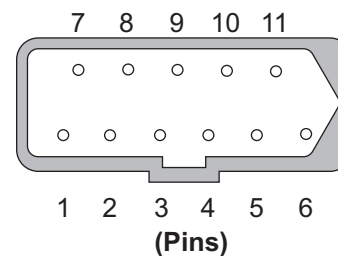

11-Pin		
Pin No.	Wire Color	Control Function
1	Black/White	PS Low Beam
2	Black/Orange	Ground
3	White/Yellow	PS High Beam
4	White	DS High Beam
5	Blue/Orange	PS Common
6	Black	DS Low Beam
7	Black/Orange	Ground
8	Gray	Left Directional
9	Purple	Right Directional
10	Brown	Parking Lights
11	Light Blue	DS Common

4-PORT & 3-PORT ISOLATION MODULE – ELECTRICAL CONNECTORS – 2-PLUG SYSTEMS

Solenoid Control Connectors

Control Side
(end view)

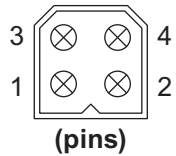

Pin No.	Solenoid Control Wire Color Only
1	Red
2	Green
3	White
4	Black

Vehicle Side
(end view)

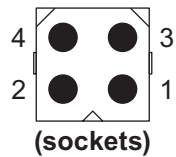

Pin No.	Wire Color	Control Function
1	Red	+12V
2	Red	Signal
3	Black	Signal
4	Black	Ground

Multiplex Harnesses

Plow (End View)

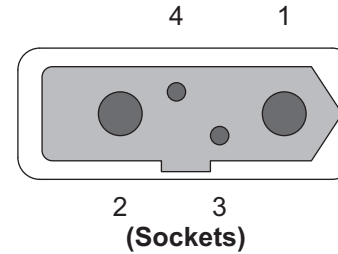

4-Pin

Pin No.	Wire Color	Control Function
1	Red	+12V
2	Black	Ground
3	Tan	Signal
4	White	Signal

Plow Lighting Harness

Plow (End View)

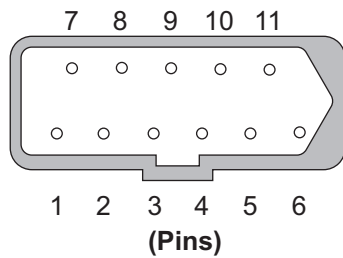

11-Pin

Pin No.	Wire Color	Control Function
1	Black/White	PS Low Beam
2	Black/Orange	Ground
3	White/Yellow	PS High Beam
4	White	DS High Beam
5	Blue/Orange	PS Common
6	Black	DS Low Beam
7	Black/Orange	Ground
8	Gray	Left Directional
9	Purple	Right Directional
10	Brown	Parking Lights
11	Light Blue	DS Common

IN-LINE ADAPTER INSTRUCTIONS – 28027-2

⚠ CAUTION

This adapter is required for vehicles equipped with a 4-headlamp lighting system that illuminates the low *and* high beams when in high-beam mode. This adapter prevents the low beams on the snowplow from illuminating when placed in high beam.

In-Line Adapter Relay Connections

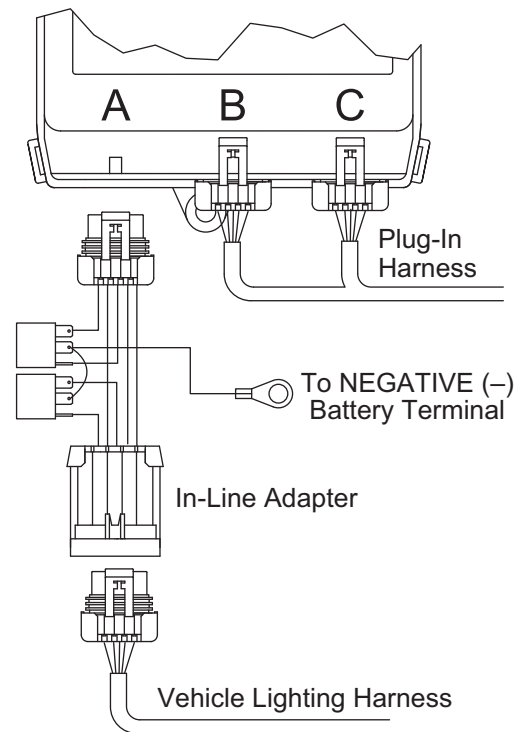
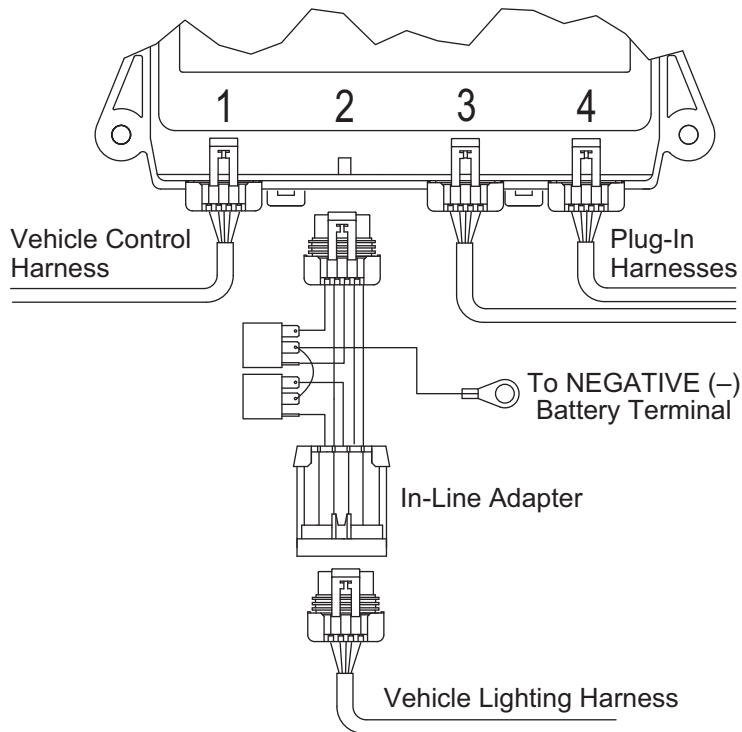
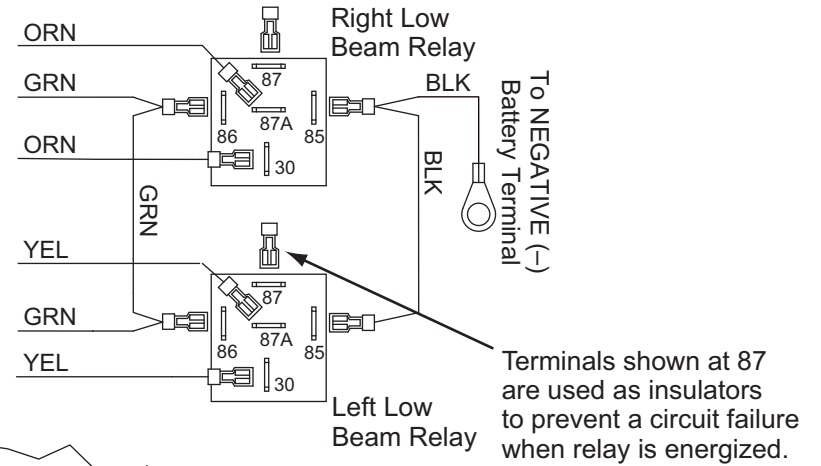

3-PORT ISOLATION MODULE – HEADLAMP INDEX

Pages	Headlamp Type	Harness Kit	Harness Part #
20	HB-3/HB-4	29048	28253
21	H13	29049	28986
22	HB-1 or HB-5	29050	28930
23	2B/2D or HB-2	29051	28464
24	HB-3/HB-4 4-Pin Connectors	29052	28924
25	2B/2D or 1A/2A 5-Pin Connectors	29053	29058
26	2B/2D 7-Pin Connectors	29054	29270
27	HB-3/H11	29400-2	29499

3-PORT ISOLATION MODULE – THEORY OF OPERATION

Overview

The Isolation Module acts as an electrical hub, automatically directing vehicle power to the appropriate vehicle or snowplow lighting devices, while also supplying battery power to the snowplow control.

The vehicle high and low beams enter and exit the Isolation Module through positions B (left side lighting) and position C (right side lighting). Park, turn, and DRL signals also enter through positions B and C.

The output of the vehicle high beam/low beam select switch is directed to

the Isolation Module via the plug-in harness. When the snowplow is not attached to the vehicle, the signal passes through the normally closed relay contacts to the vehicle headlamps. During this time, the Isolation Module is inactive, placing no current draw on the vehicle's electrical system.

With the snowplow attached, the Isolation Module is still inactive until either of the two following conditions are met: the vehicle parking lights are turned ON or the vehicle ignition switch is turned ON.

Turning ON the vehicle parking lights activates a series of relays, automatically transferring the vehicle high and low beams to the snowplow while supplying battery power directly to the snowplow parking lights. All snowplow lighting exits the Isolation Module through position A.

Turning ON the vehicle ignition switch energizes a snowplow control relay, supplying vehicle battery power directly to the control via the vehicle control harness and plug-in harness. The vehicle ignition switch also supplies power to the vehicle turn signals. Activating the vehicle turn signals energizes turn signal circuit, which supply vehicle battery power directly to the snowplow turn signals.

NOTE: References to "Left" and "Right" are correct for modules located on the driver's side of the vehicle. The reversible turn signal plug must be reversed for passenger-side installations.

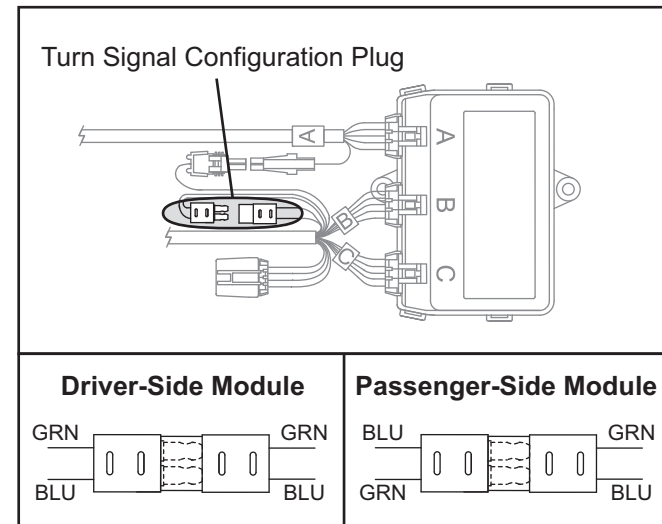

3-PORT ISOLATION MODULE – THEORY OF OPERATION

White Label Non-DRL Module (PN 29060)

Snowplow not attached to vehicle:

System is inactive. Vehicle lighting system functions normally. Reason: No ground to module.

Snowplow attached to vehicle:

System is inactive until either the switched accessory wire or the vehicle parking lights are activated. Vehicle and snowplow lighting systems function as outlined in the Theory of Operation Overview. Reason: ground path is established from battery common to Pin C on Port A of the 3-port module via the following harnesses: vehicle battery cable, vehicle control harness, adapter, plug-in harness, vehicle lighting harness and snowplow lighting harness.

- Activating a **switched accessory** wire (a key-controlled power source) applies battery voltage to the VACC input of the module, which energizes the coil of the control power relay (part of the 3-port module). Energizing the coil of the control power relay causes the relay contacts to shift from the "N.O." (normally opened) position to the "N.C." (normally closed) position, which supplies battery voltage to the snowplow control via the plug-in harness and the vehicle control harness. The switched accessory wire only controls battery voltage to the snowplow control.
- Activating the vehicle **park light** circuit applies battery voltage to the module park circuit input. The voltage is applied to a solid state power device, which causes the device to turn ON and apply battery voltage to the snowplow park lamp filaments via the vehicle and snowplow lighting harnesses. Voltage is also applied to the module's high and low beam relay coils, which causes the relay contacts to shift from the "vehicle" to the "snowplow" position.
- With the four headlamp relays shifted to the "snowplow" position, the **vehicle high and low beams** are now directed to the snowplow headlamps via the vehicle and snowplow lighting harnesses. Toggling the dimmer switch between high and low beam will toggle the snowplow high and low beams.
- Activating the **turn signal** applies battery voltage to the module turn signal circuit input. The voltage is applied to a solid state power device, which causes the device to turn ON and apply battery voltage to the snowplow turn signal lamp filaments via the vehicle and snowplow lighting harnesses.
- On vehicles equipped with **DRLs**—either integrated into the vehicle headlamps or separated into dedicated DRL lamps—this module *will not* turn OFF the vehicle DRLs or transfer them to the snowplow. DRLs will remain on the vehicle and operate as the vehicle manufacturer intended.

3-PORT ISOLATION MODULE – THEORY OF OPERATION

Green Label DRL Module (PN 29070)

Snowplow not attached to vehicle:

System is inactive. Vehicle lighting system functions normally. Reason: No ground to module.

Snowplow attached to vehicle:

System is inactive until either the switched accessory wire or the vehicle parking lights are activated. Vehicle and snowplow lighting systems function as outlined in the Theory of Operation Overview. Reason: ground path is established from battery common to Pin C on Port A of the 3-port module via the following harnesses: vehicle battery cable, vehicle control harness, adapter, plug-in harness, vehicle lighting harness and snowplow lighting harness.

- Activating a **switched accessory** wire (a key-controlled power source) applies battery voltage to the VACC input of the module. A control circuit senses the voltage and energizes the coil of the control power relay (part of the 3-port module). Energizing the coil of the control

power relay causes the relay contacts to shift from the "N.O." (normally opened) position to the "N.C." (normally closed) position, which supplies battery voltage to the snowplow control via the plug-in harness and the vehicle control harness. The switched accessory wire only controls battery voltage to the snowplow control.

- Activating the vehicle **park light** circuit applies voltage to the module park circuit input. A control circuit senses the voltage and turns ON a solid state power device, which applies battery voltage to the snowplow park lamp filaments via the vehicle and snowplow lighting harnesses.
- With the park light circuit energized, the control circuit monitors the **vehicle high and low beam** inputs. When battery voltage is sensed, the appropriate solid state power devices are turned ON, supplying battery voltage to the snowplow headlamps via the vehicle and snowplow lighting harnesses. Toggling the dimmer switch

between high and low beam will toggle the snowplow high and low beams.

- Activating the **turn signal** applies voltage to the module turn signal circuit input. A control circuit senses the voltage and turns ON a solid state power device, which applies battery voltage to the snowplow turn signal lamp filaments via the vehicle and snowplow lighting harnesses.
- **PN 29070 Only:** On vehicles equipped with **DRLs**—either integrated into the vehicle headlamps or separated into dedicated DRL lamps—**this module will not turn OFF the vehicle DRLs**. The control circuit monitors the voltage level supplied by the vehicle to the vehicle high and low beams as well as the dedicated DRL inputs. When a lower voltage is sensed on either the high or low beam inputs or battery voltage is sensed on the turn signal or dedicated DRL inputs, the control circuit turns ON the snowplow

turn signal filaments to operate as DRLs.

- **PN 29070-1 Only:** On vehicles equipped with **DRLs integrated into the vehicle headlamps**. Activation of the switched accessory wire (a key-controlled power source) Port C, Position C, applies battery voltage to the module's high and low beam relay coils, which causes the relay contacts to shift from the "vehicle" to the "snowplow" position. **This module will transfer the vehicle headlamp DRLs to the snowplow (turns off vehicle DRLs)**.
- **On vehicles equipped with dedicated DRL bulbs or vehicles using the turn signals as DRLs, this module will not turn OFF the vehicle bulbs. While the vehicle is in the DRL mode, this module will illuminate the snowplow light turn signal filaments.**

3-PORT ISOLATION MODULE – THEORY OF OPERATION

Blue Label DRL Module (PN 29760-1)

Snowplow not attached to vehicle:

System is inactive. Vehicle lighting system functions normally. Reason: No ground to module.

Snowplow attached to vehicle:

System is inactive until either the switched accessory wire or the vehicle parking lights are activated. Vehicle and snowplow lighting systems function as outlined in the Theory of Operation Overview. Reason: ground path is established from battery common to Pin C on Port A of the 3-port module via the following harnesses: vehicle battery cable, vehicle control harness, adapter, plug-in harness, vehicle lighting harness and snowplow lighting harness.

- Activating a **switched accessory** wire (a key-controlled power source) applies battery voltage to the VACC input of the module, which energizes the coil of the control power relay (part of the 3-port module). Energizing the coil of the control power relay causes the relay contacts to shift from the "N.O." (normally opened) position to the "N.C." (normally closed) position, which supplies battery voltage to the snowplow control via the plug-in harness and the vehicle control harness.
- Activating the vehicle **park light** circuit applies battery voltage to the module park circuit input. The voltage is applied to a solid state power device, which causes the device to turn ON and apply battery voltage to the snowplow park lamp filaments via the vehicle and snowplow lighting harnesses. Voltage is also applied to the module's high and low beam relay coils, which causes the relay contacts to shift from the "vehicle" to the "snowplow" position.
- With the four headlamp relays shifted to the "snowplow" position, the **vehicle high and low beams** are now directed to the snowplow headlamps via the vehicle and snowplow lighting harnesses. Toggling the dimmer switch between high and low beam will toggle the snowplow high and low beams.
- Activating the **turn signal** applies battery voltage to the module turn signal circuit input. The voltage is applied to a solid state power device, which causes the device to turn ON and apply battery voltage to the snowplow turn signal lamp filaments via the vehicle and snowplow lighting harnesses.
- On vehicles equipped with **DRLs** integrated into the vehicle headlamps, activating a **switched accessory** wire (a key-controlled power source) applies battery voltage to the module's **high and low beam** relay coils, which causes the relay contacts to shift from the "vehicle" to the "snowplow" position. This module *will* transfer the vehicle DRLs to the snowplow.

3-PORT ISOLATION MODULE – ELECTRICAL SCHEMATIC

3-PLUG STRAIGHT BLADE SNOWPLOWS (11-PIN)

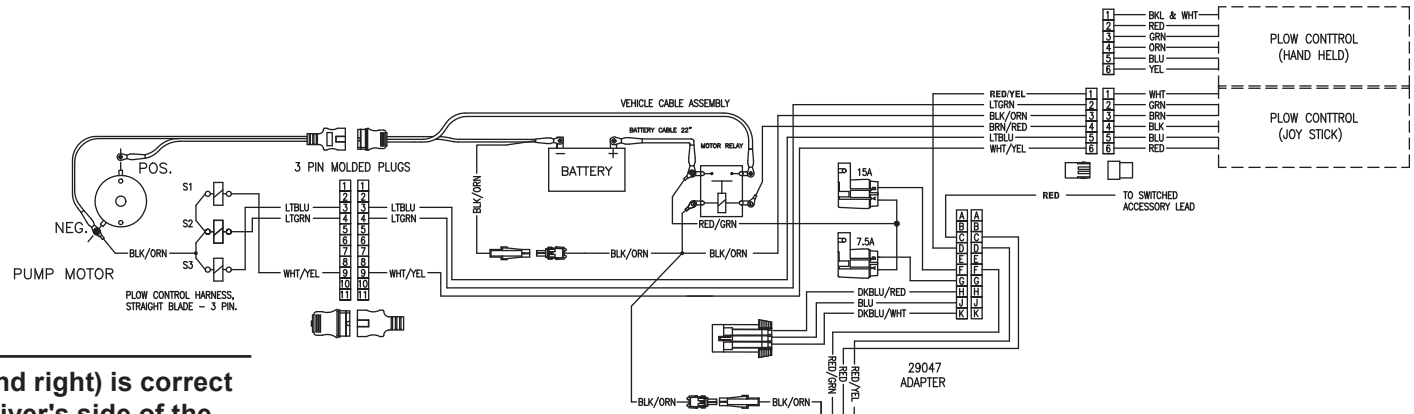

NOTE: Labeling shown (left and right) is correct for modules located on the driver's side of the vehicle. The reversible turn signal plug must be reversed for passenger-side installations.

NOTE:
LABELING SHOWN, LEFT AND RIGHT, IS CORRECT IF THE MODULE IS LOCATED ON THE DRIVER'S SIDE OF THE VEHICLE.
A REVERSIBLE TURN SIGNAL PLUG IS PROVIDED TO COMPENSATE FOR THE LEFT OR RIGHT SIDE MODULE MOUNTING REQUIREMENTS.

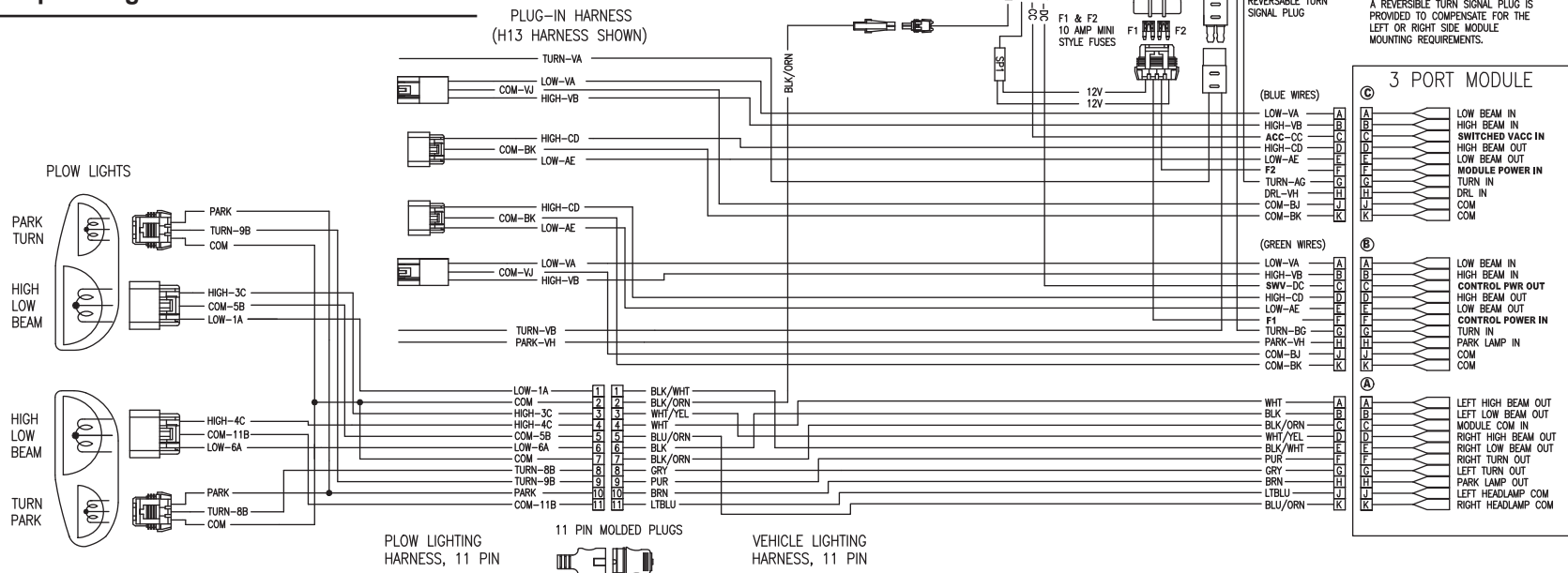

3-PORT ISOLATION MODULE – ELECTRICAL SCHEMATIC

3-PLUG MVP® SNOWPLOWS

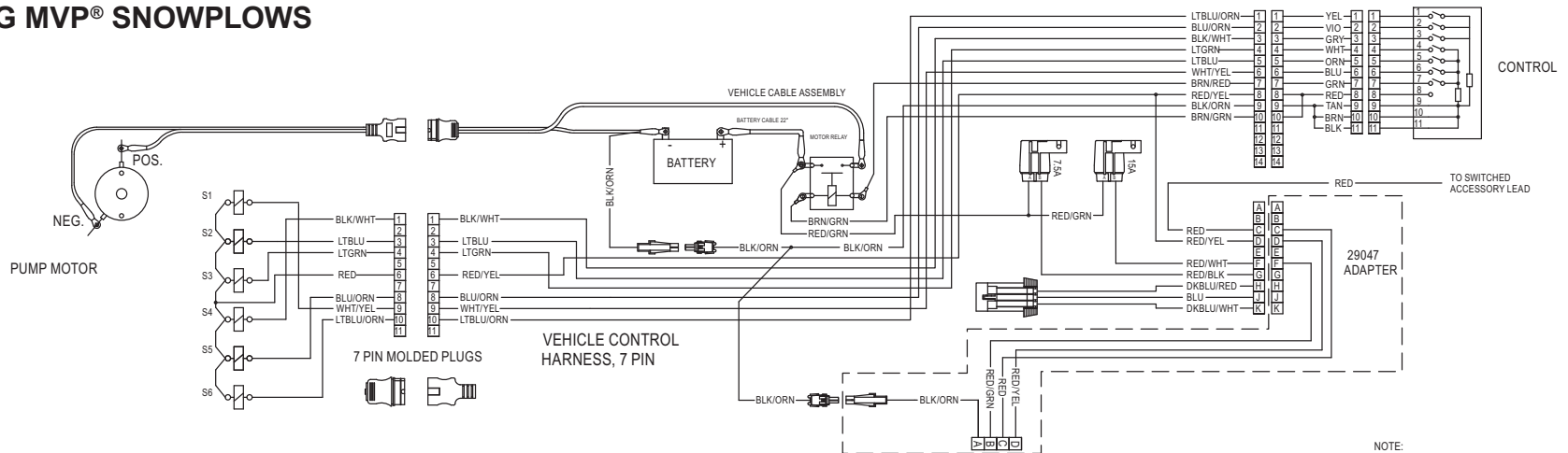

NOTE: Labeling shown (left and right) is correct for modules located on the driver's side of the vehicle. The reversible turn signal plug must be reversed for passenger-side installations.

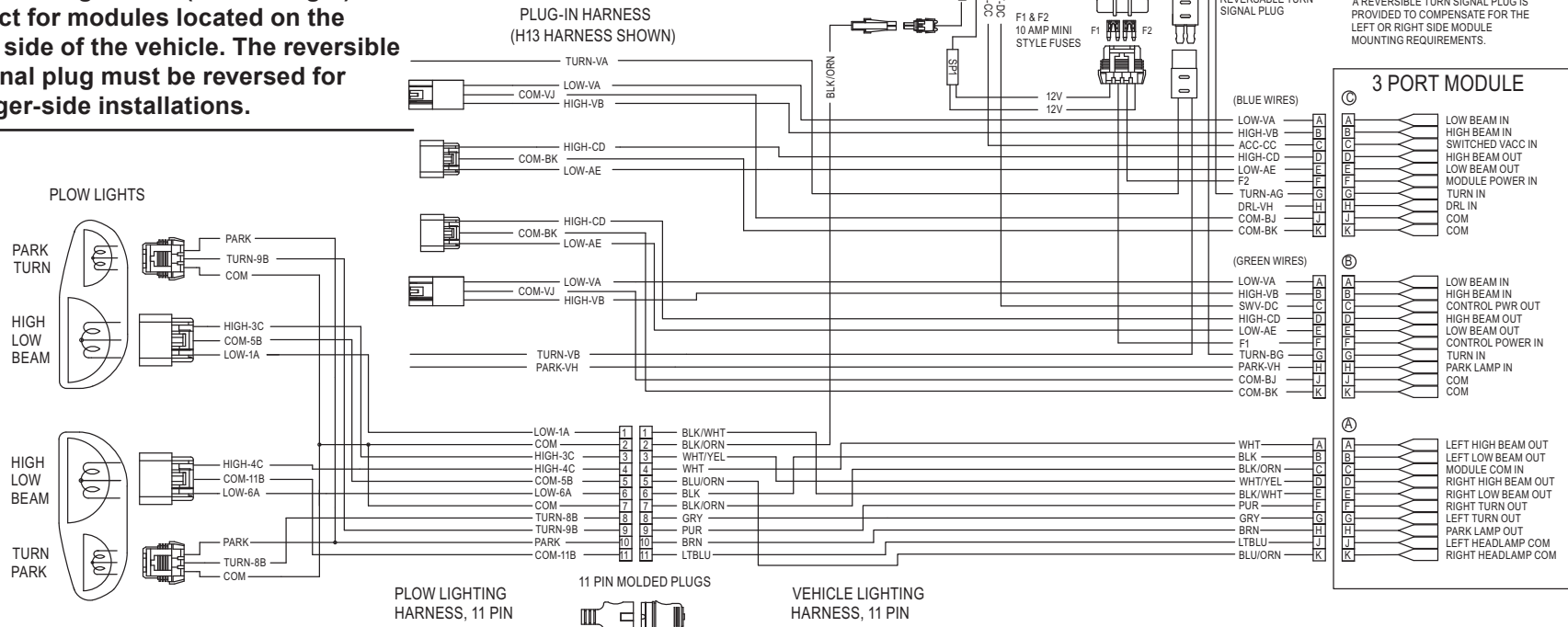

NOTE: LABELING SHOWN, LEFT AND RIGHT, IS CORRECT IF THE MODULE IS LOCATED ON THE DRIVER'S SIDE OF THE VEHICLE. A REVERSIBLE TURN SIGNAL PLUG IS PROVIDED TO COMPENSATE FOR THE LEFT OR RIGHT SIDE MODULE MOUNTING REQUIREMENTS.

3-PORT ISOLATION MODULE – ELECTRICAL SCHEMATIC

3-PLUG STRAIGHT BLADE SNOWPLOWS WITH CENTRAL HYDRAULICS

NOTE: Labeling shown (left and right) is correct for modules located on the driver's side of the vehicle. The reversible turn signal plug must be reversed for passenger-side installations.

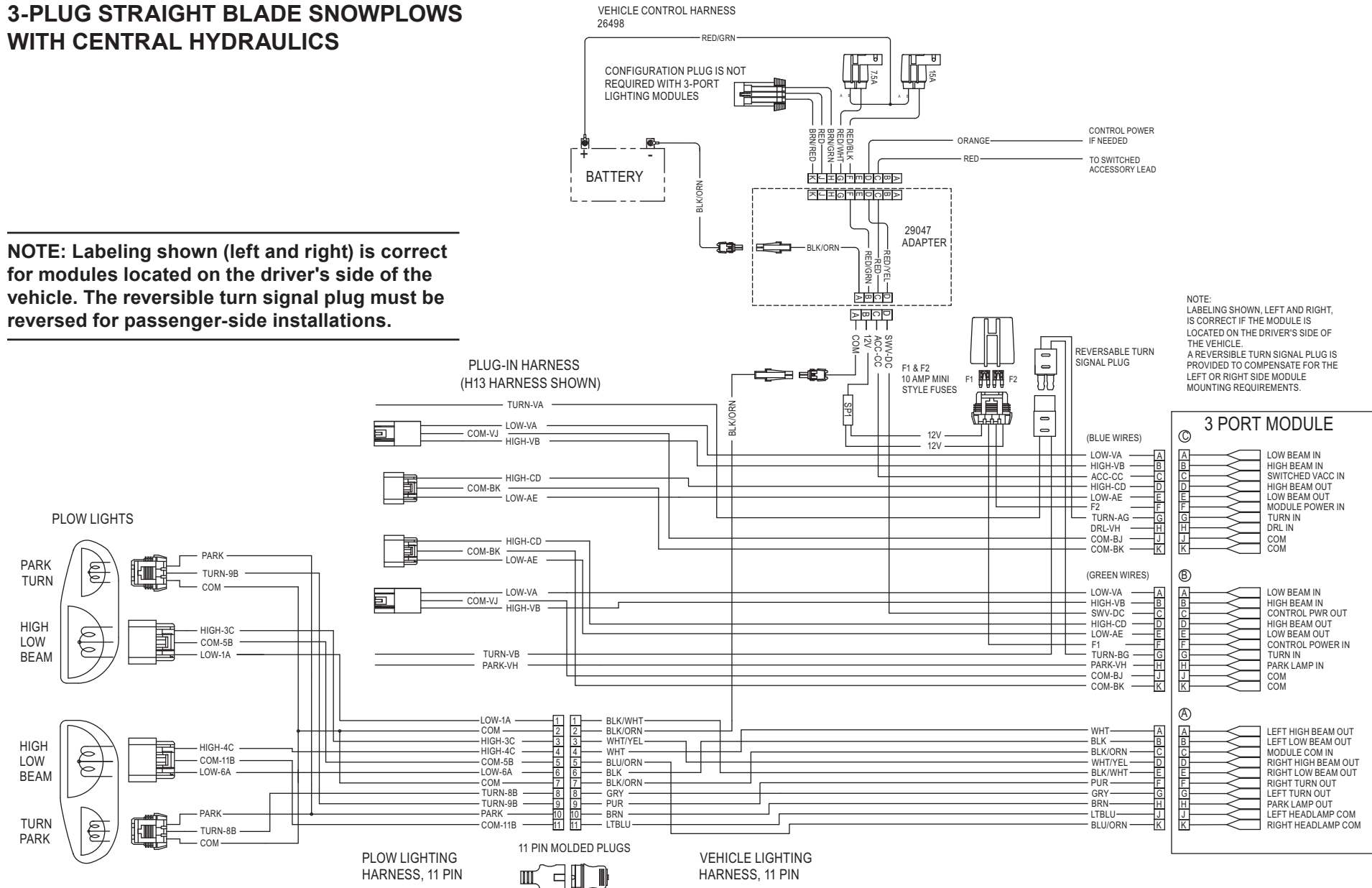

NOTE: LABELING SHOWN, LEFT AND RIGHT, IS CORRECT IF THE MODULE IS LOCATED ON THE DRIVER'S SIDE OF THE VEHICLE. A REVERSIBLE TURN SIGNAL PLUG IS PROVIDED TO COMPENSATE FOR THE LEFT OR RIGHT SIDE MODULE MOUNTING REQUIREMENTS.

3-PORT ISOLATION MODULE – ELECTRICAL SCHEMATIC

2-PLUG MVP PLUS™ SNOWPLOWS (11-PIN)

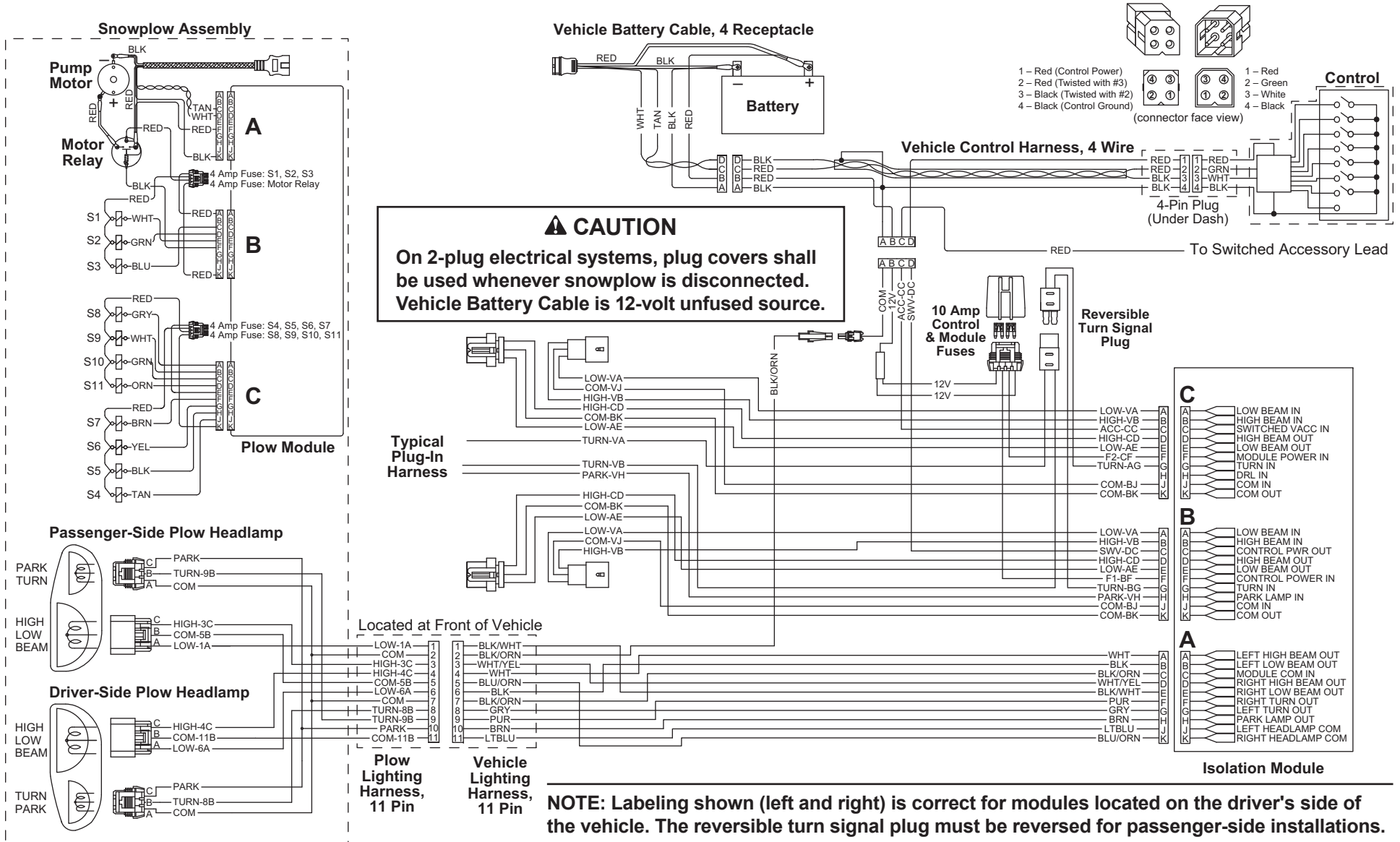

HEADLAMP WIRING – 29048 HARNESS KITS (HB-3/HB-4)

Harness Part #28253

Location	Wire Color	Stamp
Black Female Plug		
A	DK BLUE	COM-AJ
B	DK BLUE	HIGH-BB

2-Key Male Plug		
A	DK BLUE	HIGH-AD
B	DK BLUE	COM-BK

Gray Female Plug		
A	DK BLUE	COM-BA
B	DK BLUE	LOW-BA

1-Key Male Plug		
A	DK BLUE	LOW-AE
B	DK BLUE	COM-BA

Splice Tap Wires		
Loose	DK BLUE	TURN-VA

10-Position Plug "C"		
A	DK BLUE	LOW-BA
B	DK BLUE	HIGH-BB
C	RED	ACC-CC
D	DK BLUE	HIGH-AD
E	DK BLUE	LOW-AE
F	RED	F2-CF
G	DK BLUE	TURN-AG
H	DK BLUE	DRL-VH
J	DK BLUE	COM-AJ
K	DK BLUE	COM-BK

Plugs for Harness #28253

Black Female Plug

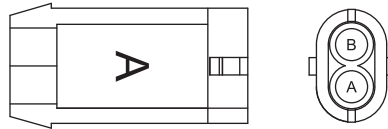

2-Key Male Plug

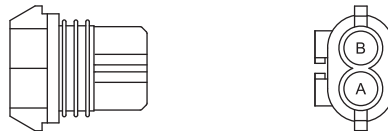

Gray Female Plug

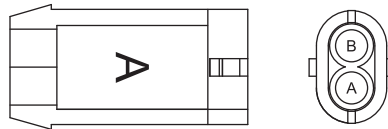

1-Key Male Plug

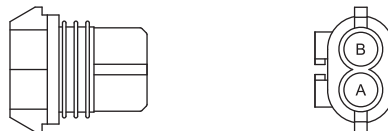

10-Position Plug for Harness #28253

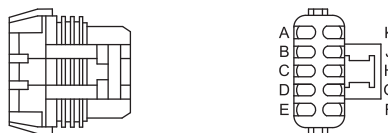

Harness Part #28253

Location	Wire Color	Stamp
Black Female Plug		
A	DK GREEN	COM-AJ
B	DK GREEN	HIGH-BB

2-Key Male Plug		
A	DK GREEN	HIGH-AD
B	DK GREEN	COM-BK

Gray Female Plug		
A	DK GREEN	COM-BA
B	DK GREEN	LOW-BA

1-Key Male Plug		
A	DK GREEN	LOW-AE
B	DK GREEN	COM-BA

Splice Tap Wires		
Loose	DK GREEN	TURN-VB
Loose	DK GREEN	PARK-VH
Loose	DK BLUE	DRL-VH

10-Position Plug "B"		
A	DK GREEN	LOW-BA
B	DK GREEN	HIGH-BB
C	RED	SWV-DC
D	DK GREEN	HIGH-AD
E	DK GREEN	LOW-AE
F	RED	F1-BF
G	DK GREEN	TURN-BG
H	DK GREEN	PARK-VH
J	DK GREEN	COM-AJ
K	DK GREEN	COM-BK

HEADLAMP WIRING – 29049 HARNESS KIT (H13)

Harness Part #28986

Location	Wire Color	Stamp
Female Plug		
A	DK BLUE	LOW-AE
B	DK BLUE	COM-BK
C	DK BLUE	HIGH-CD

Male Plug		
A	DK BLUE	LOW-AA
B	DK BLUE	COM-BJ
C	DK BLUE	HIGH-CB

Splice Tap Wires		
Loose	DK BLUE	TURN-VA

10-Position Plug "C"		
A	DK BLUE	LOW-AA
B	DK BLUE	HIGH-CB
C	RED	ACC-CC
D	DK BLUE	HIGH-CD
E	DK BLUE	LOW-AE
F	RED	F2-CF
G	DK BLUE	TURN-AG
H	—	—
J	DK BLUE	COM-BJ
K	DK BLUE	COM-BK

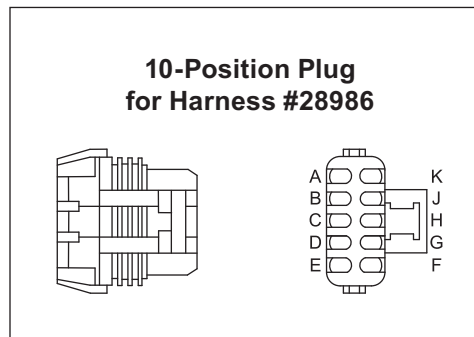
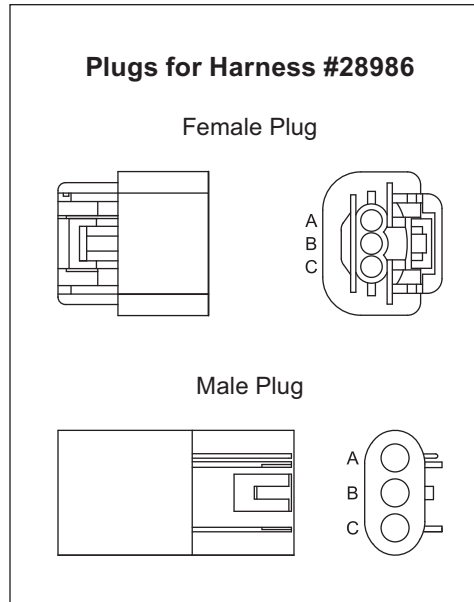

Harness Part #28986

Location	Wire Color	Stamp
Female Plug		
A	DK GREEN	LOW-AE
B	DK GREEN	COM-BJ
C	DK GREEN	HIGH-CD

Male Plug		
A	DK GREEN	LOW-AA
B	DK GREEN	COM-BK
C	DK GREEN	HIGH-CB

Splice Tap Wires		
Loose	DK GREEN	TURN-VB
Loose	DK GREEN	PARK-VH

10-Position Plug "B"		
A	DK GREEN	LOW-AA
B	DK GREEN	HIGH-CB
C	RED	SWV-DC
D	DK GREEN	HIGH-CD
E	DK GREEN	LOW-AE
F	RED	F1-BF
G	DK GREEN	TURN-BG
H	DK GREEN	PARK-VH
J	DK GREEN	COM-BJ
K	DK GREEN	COM-2K

HEADLAMP WIRING – 29050 HARNESS KIT (HB-1 OR HB-5) (1A/2A¹)

Harness Part #28930

Location	Wire Color	Stamp
Black Molded Female Plug		
1	—	—
2	DK BLUE	COM-2J
3	DK BLUE	HIGH-3B
4	DK BLUE	LOW-4A
5	—	—

Blue Molded Male Plug		
A*	DK BLUE	LOW-AE
B*	DK BLUE	COM-BK
C	DK BLUE	HIGH-CD

*Reversed for HB-1 Applications

Splice Tap Wires		
Loose	DK BLUE	TURN-VA

10-Position Plug "C"		
A	DK BLUE	LOW-4A
B	DK BLUE	HIGH-3B
C	RED	ACC-CC
D	DK BLUE	HIGH-CD
E	DK BLUE	LOW-AE
F	RED	F2-CF
G	DK BLUE	TURN-AG
H	—	—
J	DK BLUE	COM-2J
K	DK BLUE	COM-BK

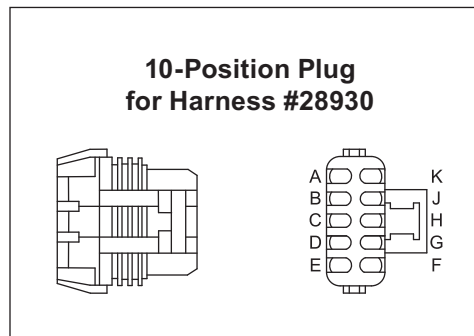
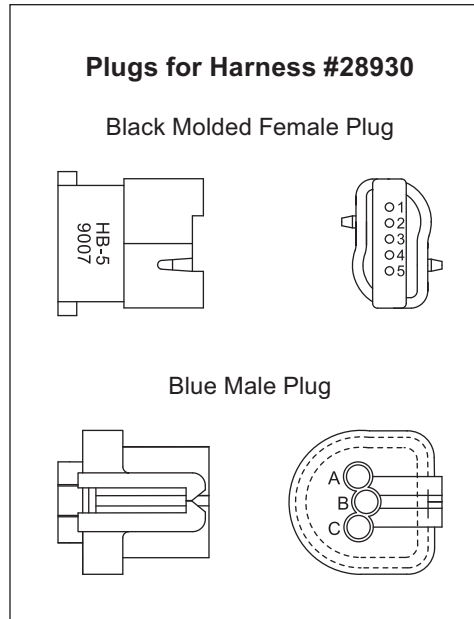

Harness Part #28930

Location	Wire Color	Stamp
Black Molded Female Plug		
1	—	—
2	DK GREEN	COM-2K
3	DK GREEN	HIGH-3B
4	DK GREEN	LOW-4A
5	—	—

Blue Molded Male Plug		
A*	DK GREEN	LOW-AE
B*	DK GREEN	COM-BJ
C	DK GREEN	HIGH-CD

*Reversed for HB-1 Applications

Splice Tap Wires		
Loose	DK GREEN	TURN-VB
Loose	DK GREEN	PARK-VH

10-Position Plug "B"		
A	DK GREEN	LOW-4A
B	DK GREEN	HIGH-3B
C	RED	SWV-DC
D	DK GREEN	HIGH-CD
E	DK GREEN	LOW-AE
F	RED	F1-BF
G	DK GREEN	TURN-BG
H	DK GREEN	PARK-VH
J	DK GREEN	COM-BJ
K	DK GREEN	COM-2K

¹Not shown. Requires adapter kit 26641.

HEADLAMP WIRING – 29051 HARNESS KIT (2B/2D)

Harness Part #28464

Location	Wire Color	Stamp
Female Plug		
A	DK BLUE	COM-AK
B	DK BLUE	LOW-BE
C	DK BLUE	HIGH-CD

Male Plug		
A	DK BLUE	HIGH-AB
B	DK BLUE	LOW-BA
C	DK BLUE	COM-CJ

Splice Tap Wires		
Loose	DK BLUE	TURN-VA

10-Position Plug "C"		
A	DK BLUE	LOW-BA
B	DK BLUE	HIGH-AB
C	RED	ACC-CC
D	DK BLUE	HIGH-CD
E	DK BLUE	LOW-BE
F	RED	F2-CF
G	DK BLUE	TURN-AG
H	—	—
J	DK BLUE	COM-BJ
K	DK BLUE	COM-AK

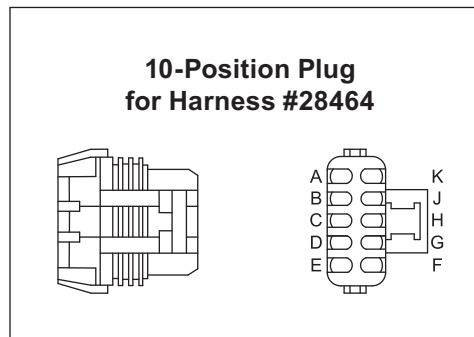
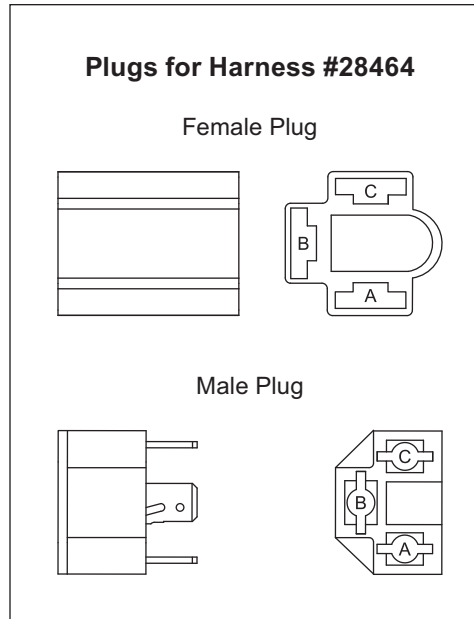

Harness Part #28464

Location	Wire Color	Stamp
Female Plug		
A	DK GREEN	COM-AK
B	DK GREEN	LOW-BE
C	DK GREEN	HIGH-CD

Male Plug		
A	DK GREEN	HIGH-AB
B	DK GREEN	LOW-BA
C	DK GREEN	COM-CJ

Splice Tap Wires		
Loose	DK GREEN	TURN-VB
Loose	DK GREEN	PARK-VH

10-Position Plug "B"		
A	DK GREEN	LOW-BA
B	DK GREEN	HIGH-AB
C	RED	SWV-DC
D	DK GREEN	HIGH-CD
E	DK GREEN	LOW-BE
F	RED	F1-BF
G	DK GREEN	TURN-BG
H	DK GREEN	PARK-VH
J	DK GREEN	COM-CJ
K	DK GREEN	COM-AK

HEADLAMP WIRING – 29052 HARNESS KIT (HB-3/HB-4)

Harness Part #28924

Location	Wire Color	Stamp
Female Plug		
A	DK BLUE	HIGH-AB
B	DK BLUE	LOW-BA
C	DK BLUE	COM-CJ
D	DK BLUE	COM-DD

Male Plug		
A	DK BLUE	HIGH-AD
B	DK BLUE	LOW-BE
C	DK BLUE	COM-CK
D	DK BLUE	COM-DD

Splice Tap Wires		
Loose	DK BLUE	TURN-VA

10-Position Plug "C"		
A	DK BLUE	LOW-BA
B	DK BLUE	HIGH-AB
C	RED	ACC-CC
D	DK BLUE	HIGH-AD
E	DK BLUE	LOW-BE
F	RED	F2-CF
G	DK BLUE	TURN-AG
H	—	—
J	DK BLUE	COM-CJ
K	DK BLUE	COM-CK

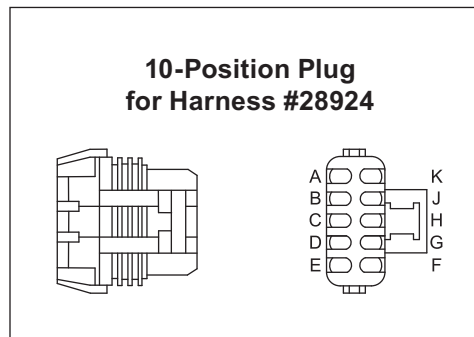
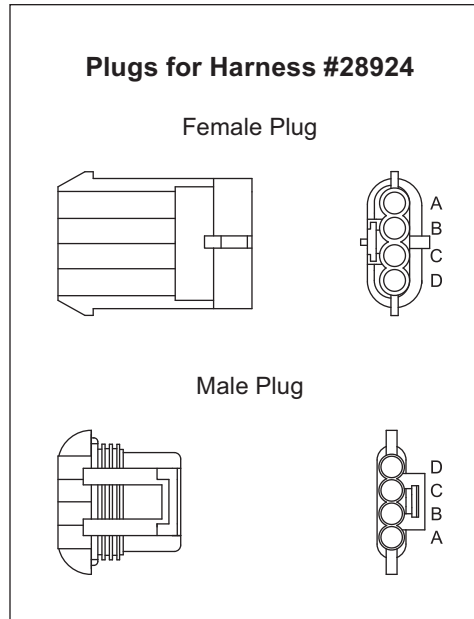

Harness Part #28924

Location	Wire Color	Stamp
Female Plug		
A	DK GREEN	HIGH-AB
B	DK GREEN	LOW-BA
C	DK GREEN	COM-CK
D	DK GREEN	COM-DD

Male Plug		
A	DK GREEN	HIGH-AD
B	DK GREEN	LOW-BE
C	DK GREEN	COM-CJ
D	DK GREEN	COM-DD

Splice Tap Wires		
Loose	DK GREEN	TURN-VB
Loose	DK GREEN	PARK-VH

10-Position Plug "B"		
A	DK GREEN	LOW-BA
B	DK GREEN	HIGH-AB
C	RED	SWV-DC
D	DK GREEN	HIGH-AD
E	DK GREEN	LOW-BE
F	RED	F1-BF
G	DK GREEN	TURN-BG
H	DK GREEN	PARK-VH
J	DK GREEN	COM-CJ
K	DK GREEN	COM-CK

HEADLAMP WIRING – 29053 HARNESS KIT (2B/2D OR 1A/2A)

Harness Part #29058

Location	Wire Color	Stamp
Female Plug		
A	DK BLUE	HIGH-AD
B	DK BLUE	LOW-BE
C	DK BLUE	COM-CJ
D	DK BLUE	TURN
E	DK BLUE	PARK

Male Plug		
A	DK BLUE	HIGH-AB
B	DK BLUE	LOW-BA
C	DK BLUE	COM-CK
D	DK BLUE	TURN
E	DK BLUE	PARK

10-Position Plug "C"		
A	DK BLUE	LOW-BA
B	DK BLUE	HIGH-AB
C	RED	ACC-CC
D	DK BLUE	HIGH-AD
E	DK BLUE	LOW-BE
F	RED	F2-CF
G	DK BLUE	TURN-AG
H	—	—
J	DK BLUE	COM-CJ
K	DK BLUE	COM-CK

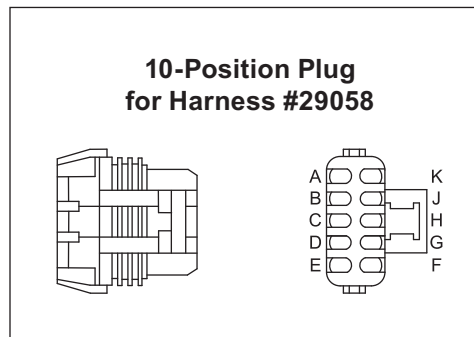
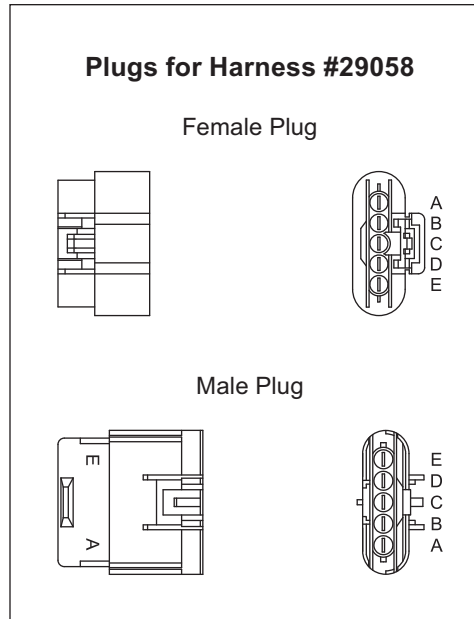

Harness Part #29058

Location	Wire Color	Stamp
Female Plug		
A	DK GREEN	HIGH-AD
B	DK GREEN	LOW-BE
C	DK GREEN	COM-CK
D	DK GREEN	TURN
E	DK GREEN	PARK

Male Plug		
A	DK GREEN	HIGH-AB
B	DK GREEN	LOW-BA
C	DK GREEN	COM-CJ
D	DK GREEN	TURN
E	DK GREEN	PARK

10-Position Plug "B"		
A	DK GREEN	LOW-BA
B	DK GREEN	HIGH-AB
C	RED	SWV-DC
D	DK GREEN	HIGH-AD
E	DK GREEN	LOW-BE
F	RED	F1-BF
G	DK GREEN	TURN-BG
H	DK GREEN	PARK
J	DK GREEN	COM-CJ
K	DK GREEN	COM-CK

HEADLAMP WIRING – 29054 HARNESS KIT (2B/2D)

Harness Part #29270

Location	Wire Color	Stamp
7-Pin Female Plug		
A	BLACK	PARK
B	BLACK	LOW
C	BLACK	L TURN
D	BLACK	R TURN
E	BLACK	HIGH
F	—	—
G	BLACK	COM

7-Pin Male Plug		
A	BLACK	PARK
B	BLACK	LOW
C	BLACK	L TURN
D	BLACK	R TURN
E	BLACK	HIGH
F	—	—
G	BLACK	COM

10-Position Plug "C"		
A	BLACK	LOW
B	BLACK	HIGH
C	RED	ACC
D	—	—
E	—	—
F	RED	F2
G	BLACK	R TURN
H	—	—
J	—	—
K	BLACK	COM

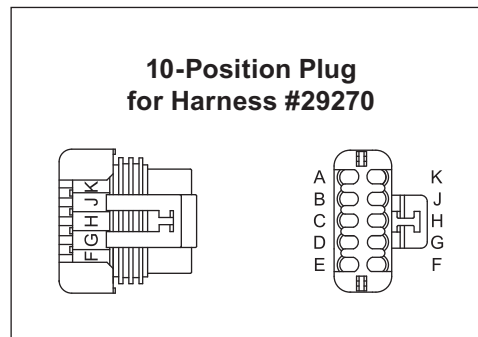
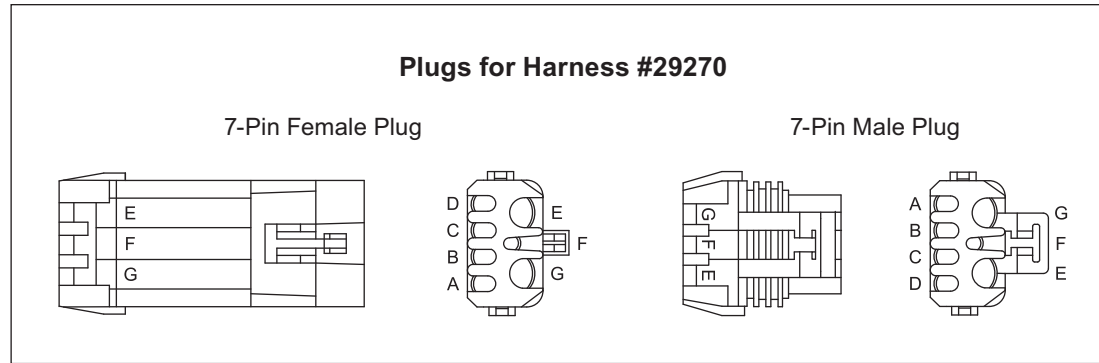

Harness Part #29270

Location	Wire Color	Stamp
10-Position Plug "B"		
A	BLACK	LOW
B	BLACK	HIGH
C	RED	SWV
D	BLACK	HIGH
E	BLACK	LOW
F	RED	F1
G	BLACK	L TURN
H	BLACK	PARK
J	BLACK	COM
K	BLACK	COM

HEADLAMP WIRING – 29400-2 HARNESS KITS (HB-3/H11)

Harness Part #29499

Location	Wire Color	Stamp
HB-3 Female Plug		
A	DK BLUE	COM-AJ
B	DK BLUE	HIGH-BB

HB-3 Male Plug		
A	DK BLUE	HIGH-AD
B	DK BLUE	COM-BK

H11 Female Plug		
A	DK BLUE	COM-AA
B	DK BLUE	LOW-BA

H11 Male Plug		
A	DK BLUE	COM-AA
B	DK BLUE	LOW-BE

Splice Tap Wires		
Loose	DK BLUE	TURN-VA

10-Position Plug "C"		
A	DK BLUE	LOW-BA
B	DK BLUE	HIGH-BB
C	RED	ACC-CC
D	DK BLUE	HIGH-AD
E	DK BLUE	LOW-BE
F	RED	F2-CF
G	DK BLUE	TURN-AG
H	DK BLUE	DRL-VH
J	DK BLUE	COM-AJ
K	DK BLUE	COM-BK

Plugs for Harness #29499

HB-3 Female Plug

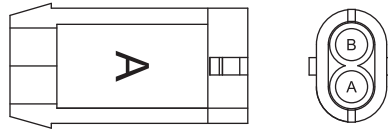

HB-3 Male Plug

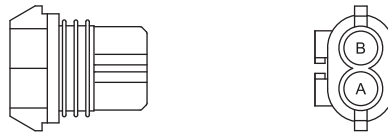

H11 Female Plug

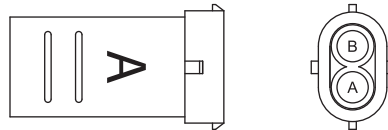

H11 Male Plug

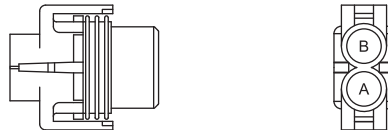

10-Position Plug for Harness #29499

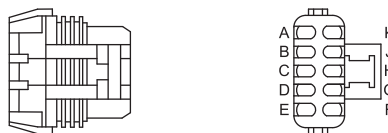

Harness Part #29499

Location	Wire Color	Stamp
HB-3 Female Plug		
A	DK GREEN	COM-AJ
B	DK GREEN	HIGH-BB

HB-3 Male Plug		
A	DK GREEN	HIGH-AD
B	DK GREEN	COM-BK

H11 Female Plug		
A	DK GREEN	COM-AA
B	DK GREEN	LOW-BA

H11 Male Plug		
A	DK GREEN	COM-AA
B	DK GREEN	LOW-BE

Splice Tap Wires		
Loose	DK GREEN	TURN-VB
Loose	DK GREEN	PARK-VH
Loose	DK BLUE	DRL-VH

10-Position Plug "B"		
A	DK GREEN	LOW-BA
B	DK GREEN	HIGH-BB
C	RED	SWV-DC
D	DK GREEN	HIGH-AD
E	DK GREEN	LOW-BE
F	RED	F1-BF
G	DK GREEN	TURN-BG
H	DK GREEN	PARK-VH
J	DK GREEN	COM-AJ
K	DK GREEN	COM-BK

4-PORT ISOLATION MODULE – HEADLAMP INDEX

Headlamp Type	Vehicle(s)	Year(s)	Page	Isolation Module Kit #	Short Plug-in	Long Plug-in	Isolation Module #
H13	Ford F-150 (New Body Style)	'04–Present	45	28400	28244	28242	26400
	Ford Super Duty	'05–Present					
	Dodge 1500, 2500, 3500	'06–Present					
	Dodge Dakota	'05–Present					
	Dodge Durango	'04–Present					
	GMC Yukon/Yukon XL (All New)	'07–Present					
HB-3/H11	Chevy/GMC 1500/2500/3500 (All New)	'07–Present	42	28400, 28027-2, 29420-1	26351	26352	27781
	Toyota Tundra	'07–Present					
	Chevy/GMC Tahoe/Suburban (All New)	'07–Present		27780, 29458, 28027-2			
HB-3/HB-4	Chevy/GMC Trailblazer/Envoy/Bravada	'02–Present	44	28028	28032	28030	26400
	Chevy/GMC Blazer/Jimmy/S-10/Sonoma	'98–Present	41	27480-1	26361	26360	
	Chevy/GMC Colorado/Canyon (US vehicles)	'04–Present					
	Nissan Titan	'04–Present					
	Chevy/GMC 1500/2500/3500 (New Body Style)	'99–'02	42	8437-1	26351	26352	27781
	Chevy/GMC Colorado/Canyon (Canadian vehicles)	'04–Present		8437-1 & 28555			
	Chevy/GMC 1500/2500/3500/Avalanche	'03–Present		27780			
	Chevy/GMC (Classic Style)	'90–'02	42	8438	26351	26352	26400
	Chevy/GMC Blazer/Jimmy/S-10/Sonoma	'95–'97		8438 & 28027			
Ford Explorer	'02–Present						
2B/2D or HB-2	Jeep	'84–'02	38	8439	26356	26353	26400
	Dodge	'72–'93					
	Ford	'80–Present					
	Chevy/GMC	'73–'02					
	Toyota	'84–Present					
	International	'89–'02					
2E	Chevy/GMC Blazer/Jimmy/S-10/Sonoma	'95–'97	43	27890	27885	27886	26400
	Dodge Dakota	'87–'96					
2B/2D or 1A/2A	Chevy/GMC C4500/5500	'03–Present	40	8443	n/a	26638	26400
2B/2D	Chevy/GMC Topkick/Kodiak 4500/5500	'90–'02	39	8442	26372	26370	
HB-5/HB-1 (Quad)	Dodge	'99–'02	37	8436	26349	26354	
HB-1 or HB-5	Dodge	'91–Present					
	Ford	'80–Present					
	Mazda	'91–'94, '99–'03					
	Toyota 4Runner	'92–'95					
	Jeep Liberty	'02–Present					
	Mitsubishi FG	'05–Present					
International	'03–Present	8436 & 28860					
1A/2A	Dodge	'74–'83					8436 & 26640
	Chevy/GMC	'73–'87	8436 & 26641				
	Isuzu/Mitsubishi	'94–'97					
LF/UF	Jeep Wagoneer	'85–'91	45	28400 & B62225	28244	28242	
	Chevy/GMC	'88–'91					

4-PORT ISOLATION MODULE – THEORY OF OPERATION

SNOWPLOW HEADLAMPS

The Isolation Module acts as an electrical hub, automatically directing vehicle power to the appropriate vehicle or snowplow lighting devices, while also supplying battery power to the snowplow control.

The vehicle high and low beams enter and exit the Isolation Module through positions 3 (left-side lighting) and position 4 (right-side lighting). Park, turn and DRL signals also enter through positions 3 and 4. The output of the vehicle dimmer switch is directed to the Isolation Module via the long and short plug-in harnesses.

All snowplow lighting exits the Isolation Module through position 2.

When the snowplow is not attached to the vehicle, the signal passes through the normally closed relay contacts to the vehicle headlamps. During this time, the Isolation Module is inactive, placing no current draw on the vehicle's electrical system.

With the snowplow attached, the Isolation Module is still inactive until either of the two following conditions are met: The vehicle parking lights are turned ON or the vehicle ignition switch is turned ON.

Turning ON the vehicle parking lights activates a series of relays, automatically transferring the vehicle high and low beams to the snowplow while supplying battery power directly to the snowplow parking lights.

Turning ON the vehicle ignition switch energizes a snowplow control relay, supplying vehicle battery power directly to the control via the vehicle control harness. The vehicle ignition switch also supplies power to the vehicle turn signals. Activating the vehicle turn signals energizes turn signal relays, which supply vehicle battery power directly to the snowplow turn signals.

SNOWPLOW DAYTIME RUNNING LIGHTS

Because Daytime Running Lamps (DRLs) are controlled differently on some vehicles, two Isolation Modules have been developed.

The white Isolation Module transfers the DRL output from the vehicle headlamps to the snowplow headlamps when the vehicle ignition switch is turned ON and the snowplow is attached.

The green Isolation Module, designed for vehicles with dedicated DRL bulbs, senses the vehicle in the DRL mode and a series of relays energize, placing the snowplow low beams in series. This Isolation Module does not turn OFF the vehicle's dedicated DRLs.

4-PORT ISOLATION MODULE SYSTEM

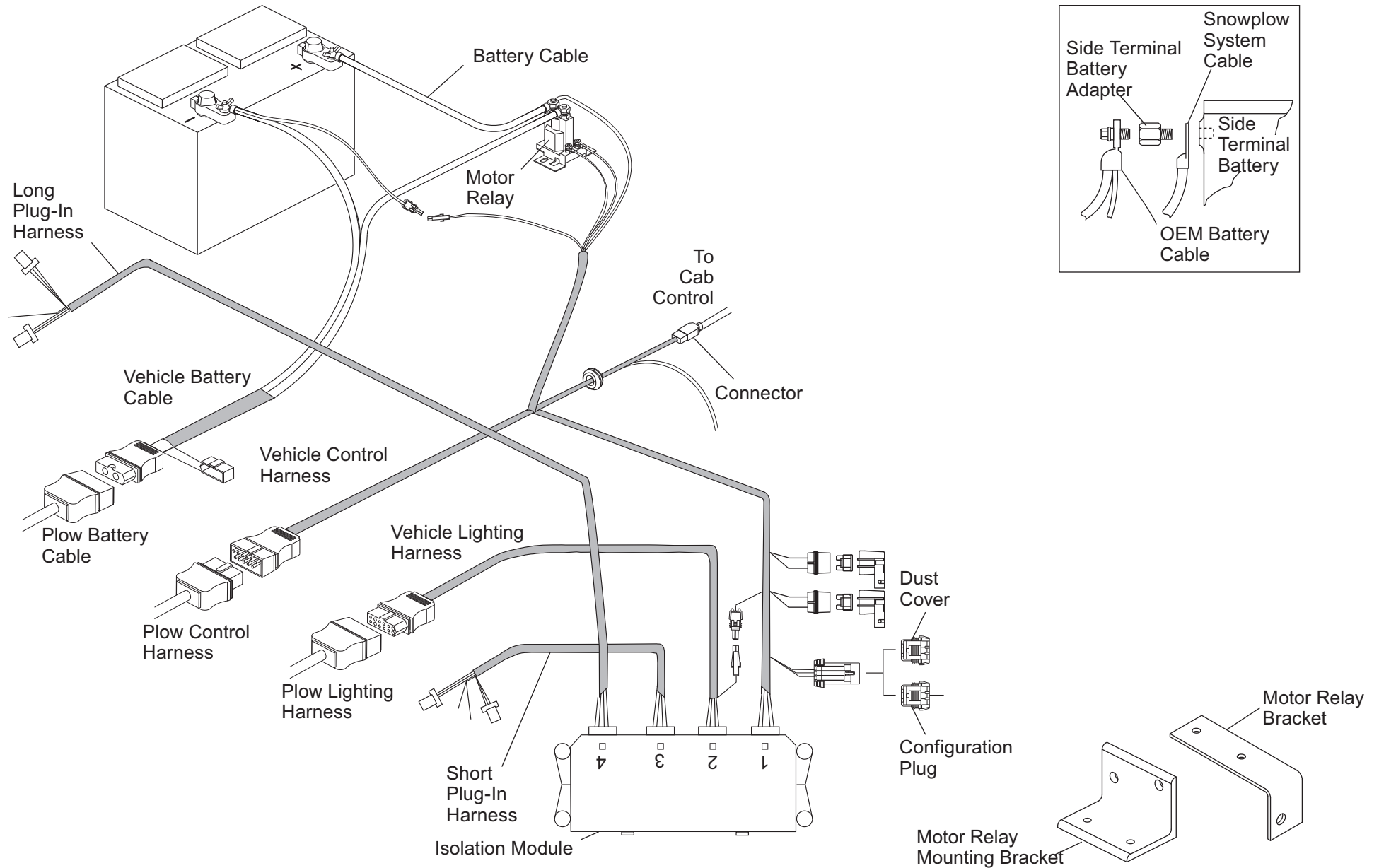

4-PORT ISOLATION MODULE SYSTEM – ADAPTER KITS

Plug-In Adapter w/Park

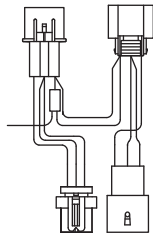

Adapter Kit HB-5 to HB-2 (PN 28860-1)

Plug-In Adapter w/o Park

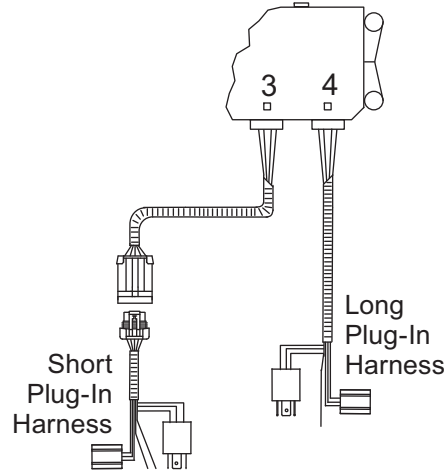
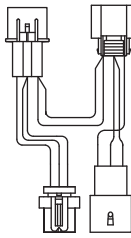

Extension Harness Kit (PN 26640)

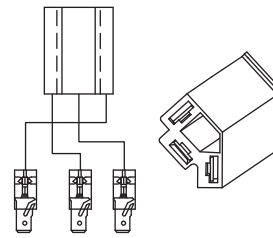

Adapter Kit 2B to 2E (PN 27968-1)

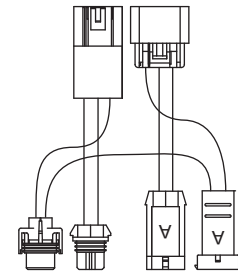

Adapter Kit H13 to HB-3/H11 (PN 29420-1)

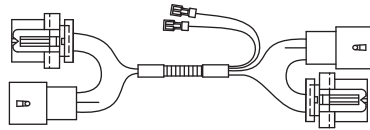

Adapter Kit HB-1 (PN 29056-1)

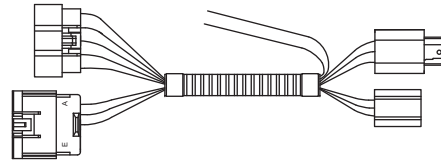

Adapter Kit 2B/2D (PN 29234)

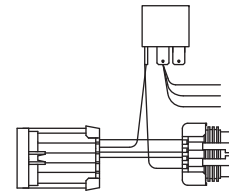

Adapter Kit (PN 28555)

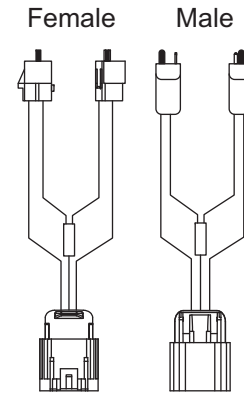

Adapter Kit H13 to LF/UF (PN B62225-1)

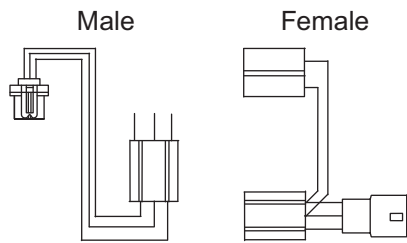

Adapter Kit HB-5 to 1A/2A (PN 26641-1)

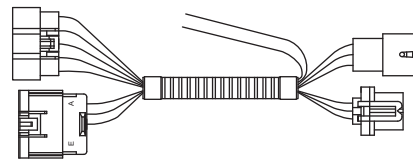

Adapter Kit HB-5 (PN 29235)

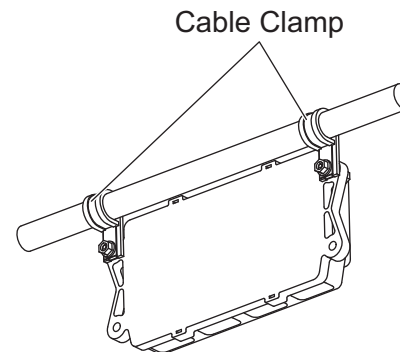

Cable Clamp

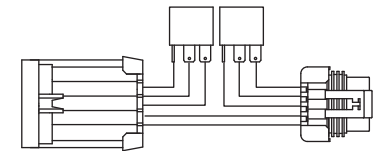

In-Line Adapter (PN 28027-2)

CONFIGURATION PLUG INSTRUCTIONS – 26421

PLUG CONFIGURATION

Headlamp Common = Negative

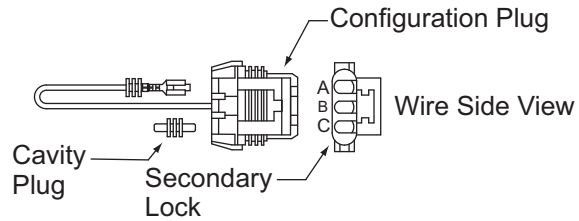

1. Jumper Position B to Position A
2. Insert cavity plug into Position C
3. Install secondary lock

Headlamp Common = Positive

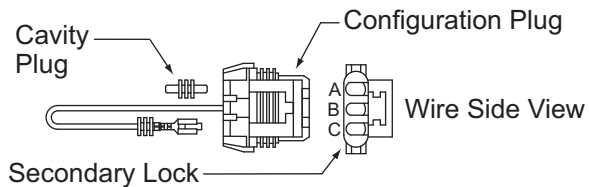

1. Jumper Position B to Position C
2. Insert cavity plug into Position A
3. Install secondary lock

To insert terminal or jumper wire into position:

1. Push terminal into correct cavity,
2. Listen for a click. If terminal pulls out, carefully bend locking tab outward and reinstall terminal.

NOTE: If unsure of headlamp common, configure plug for a negative common. Complete the installation and check headlamp functions. Turn on the vehicle lights in the low beam mode. Both low beams should be on. If the left low beam does not illuminate, change plug configuration to positive common and test headlamp functions.

Some applications will not use the configuration plug and will be supplied with a "Dust Cover".

4-PORT ISOLATION MODULE – ELECTRICAL SCHEMATIC

3-PLUG STRAIGHT BLADE SNOWPLOWS (3-PIN)

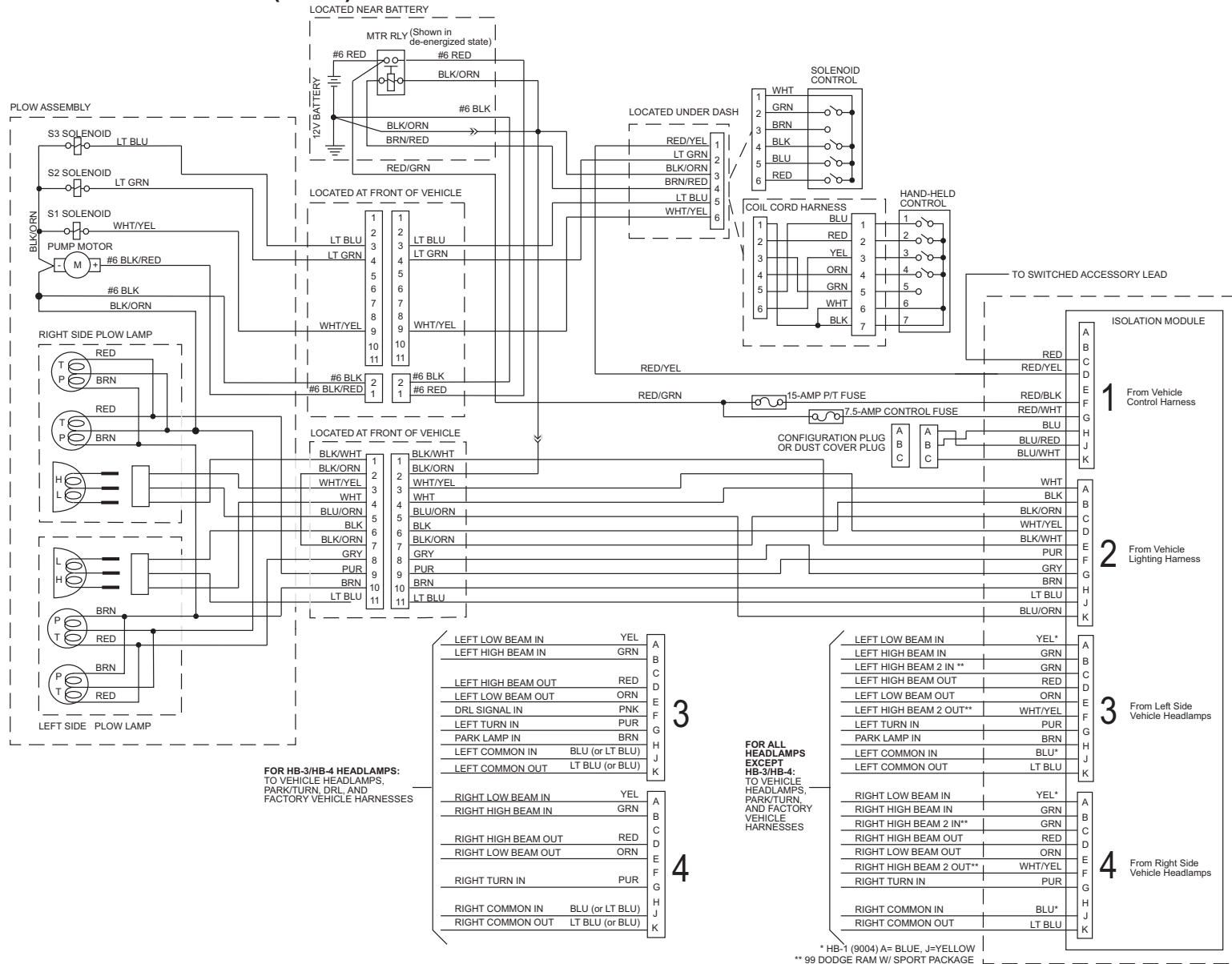

4-PORT ISOLATION MODULE – ELECTRICAL SCHEMATIC

2-PLUG MVP PLUS™ SNOWPLOWS

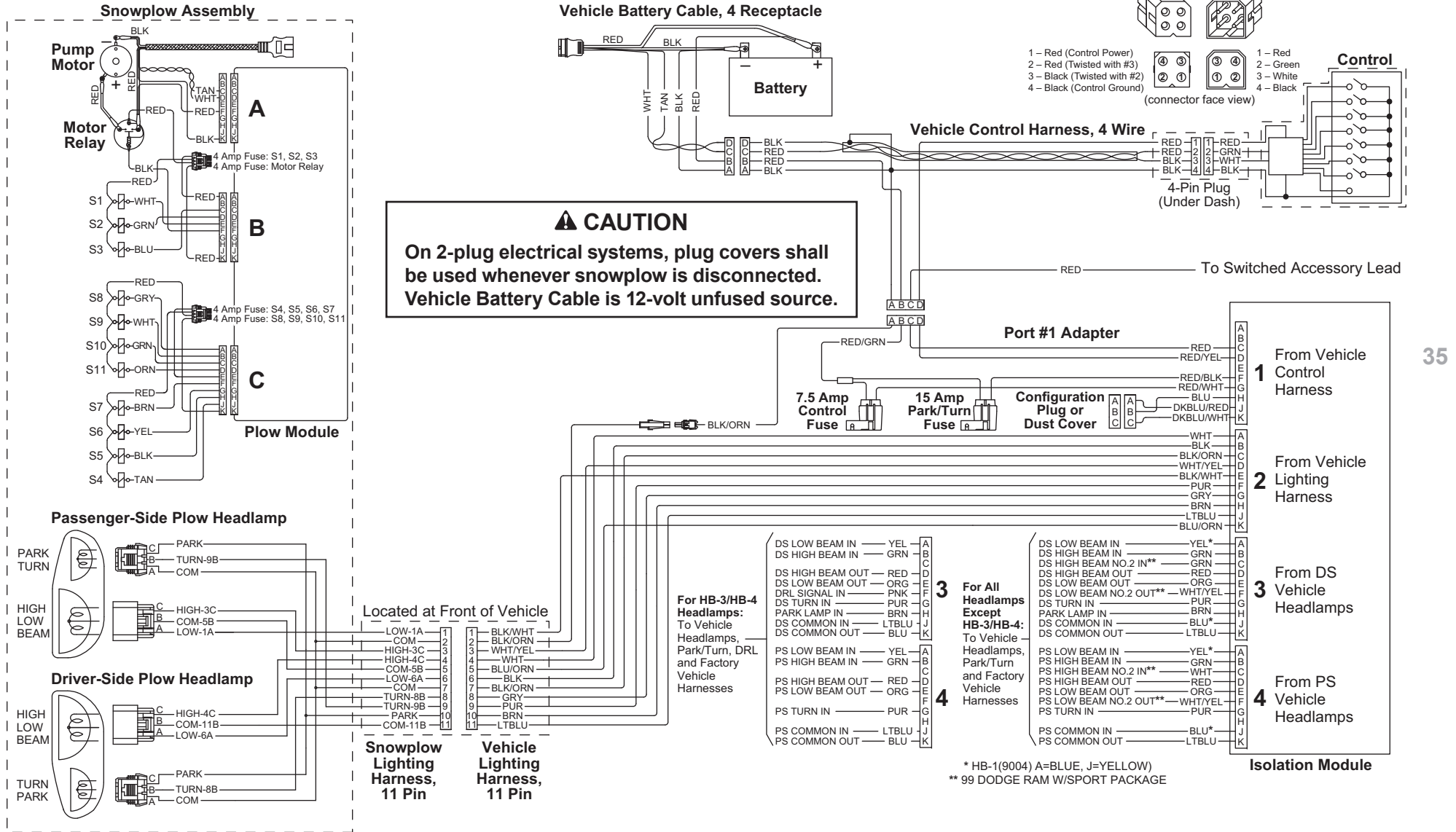

4-PORT ISOLATION MODULE – ELECTRICAL SCHEMATIC

2-PLUG WIDE-OUT™ SNOWPLOWS

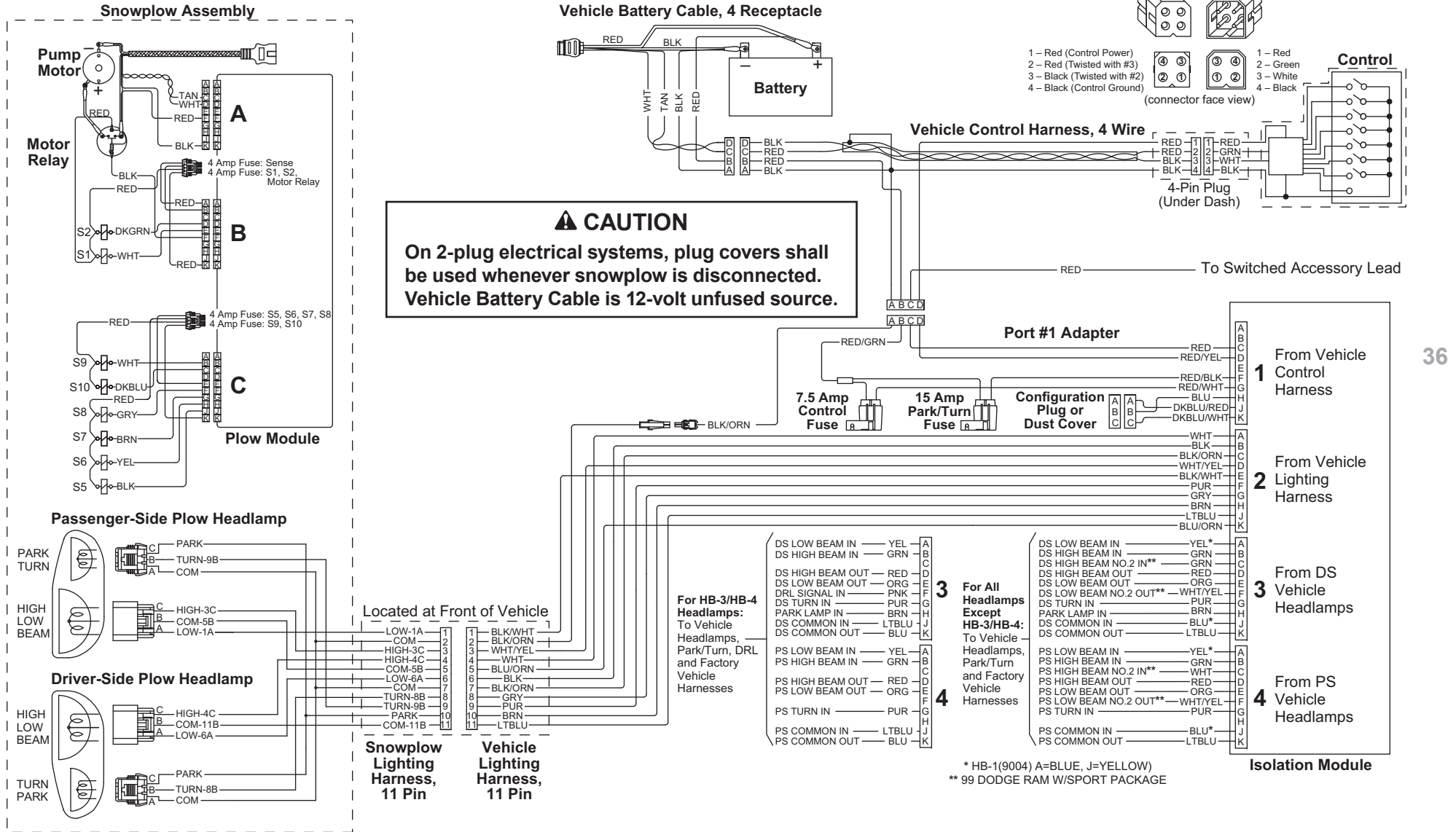

HEADLAMP WIRING – 8436 HARNESS KIT (HB-1 OR HB-5) (1A/2A¹)

Harness Part #26349

Location	Wire Color
Black Molded Female Plug	
1	GREEN
2	BLUE
3	YELLOW

Blue Male Plug	
A	LT BLUE* / ORANGE**
B	ORANGE* / LT BLUE**
C	RED

* HB-1 ** HB-5

Splice Tap Wires	
Loose	PURPLE
Loose	BROWN

10-Position Plug	
A	BLUE* / YELLOW**
B	GREEN
C	—
D	RED
E	ORANGE
F	—
G	PURPLE
H	BROWN
J	YELLOW* / BLUE**
K	LT BLUE

Plugs for Harnesses #26349 and #26354

Black Molded Female Plug

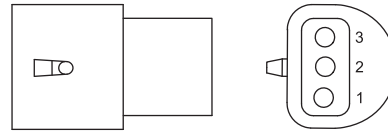

Blue Male Plug

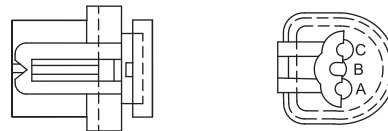

10-Position Plug for Harnesses #26349 and #26354

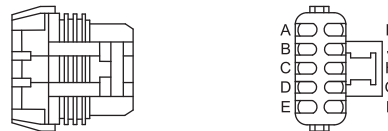

Harness Part #26354

Location	Wire Color
Black Molded Female Plug	
1	GREEN
2	BLUE
3	YELLOW

Blue Male Plug	
A	LT BLUE* / ORANGE**
B	ORANGE* / LT BLUE**
C	RED

* HB-1 ** HB-5

Splice Tap Wires	
Loose	PURPLE

10-Position Plug	
A	BLUE* / YELLOW**
B	GREEN
C	—
D	RED
E	ORANGE
F	—
G	PURPLE
H	—
J	YELLOW* / BLUE**
K	LT BLUE

¹ Not shown. Requires adapter kit 26641.

HEADLAMP WIRING – 8439 HARNESS KIT (2B/2D) (2E¹)

Harness Part #26353

Location	Wire Color
Female Plug	
A	LT BLUE
B	ORANGE
C	RED

Male Plug	
A	GREEN
B	YELLOW
C	BLUE

Splice Tap Wires	
Loose	PURPLE

10-Position Plug	
A	YELLOW
B	GREEN
C	—
D	RED
E	ORANGE
F	—
G	PURPLE
H	—
J	BLUE
K	LT BLUE

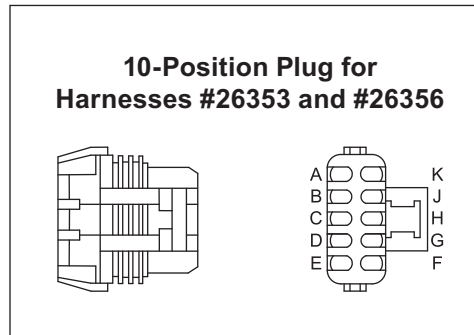
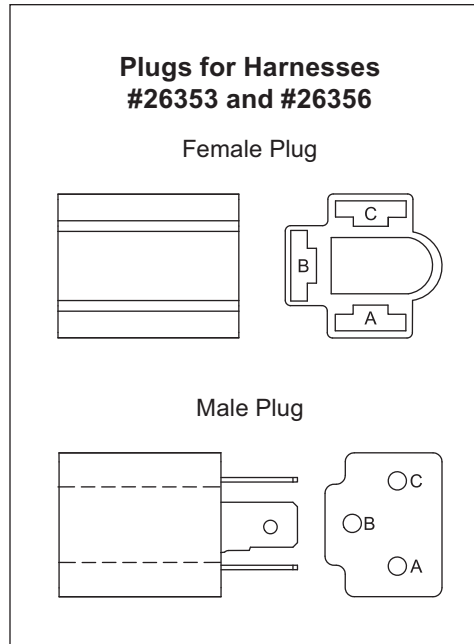

Harness Part #26356

Location	Wire Color
Female Plug	
A	ORANGE
B	LT BLUE
C	RED

Male Plug	
A	YELLOW
B	BLUE
C	GREEN

Splice Tap Wires	
Loose	PURPLE
Loose	BROWN

10-Position Plug	
A	YELLOW
B	GREEN
C	—
D	RED
E	ORANGE
F	—
G	PURPLE
H	BROWN
J	BLUE
K	LT BLUE

¹ Not shown. Requires adapter kit 27698.

HEADLAMP WIRING – 8442 HARNESS KIT (HB-1/HB-5 QUAD)

Harness Part #26370

Location	Wire Color
Black Molded Female Plug (3 Wire)	
1	GREEN
2	BLUE
3	YELLOW
Blue Male Plug	
A	ORANGE
B	LT BLUE
C	RED
Black Molded Plug (2 Wire)	
1	GREEN
2	—
3	YELLOW
Blue Female Plug (2 Wire)	
A	YELLOW
B	—
C	WHITE / YELLOW
Splice Tap Wires	
Loose	PURPLE
10-Position Plug	
A	YELLOW
B	GREEN
C	GREEN
D	RED
E	ORANGE
F	WHITE / YELLOW
G	PURPLE
H	—
J	BLUE
K	LT BLUE

Plugs for Harness #26370 & #26372

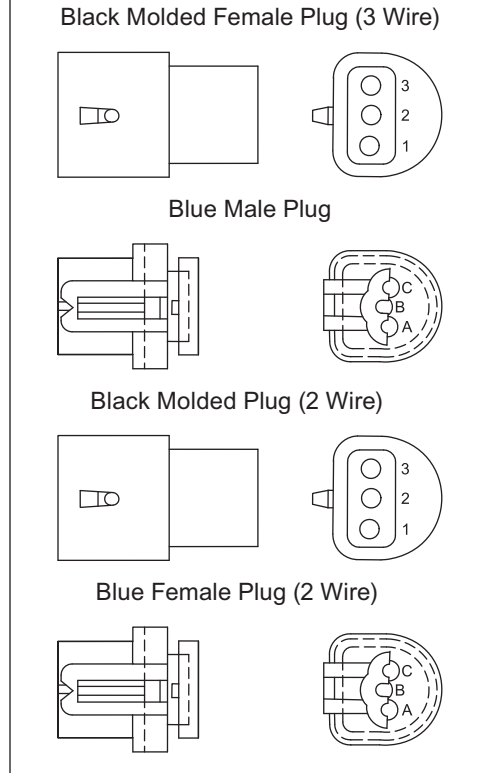

10-Position Plug for Harness #26370 & #26372

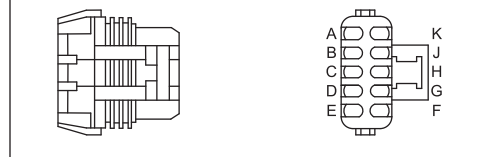

Harness Part #26372

Location	Wire Color
Black Molded Female Plug (3 Wire)	
1	GREEN
2	BLUE
3	YELLOW
Blue Male Plug	
A	ORANGE
B	LT BLUE
C	RED
Black Molded Plug (2 Wire)	
1	GREEN
2	—
3	YELLOW
Blue Female Plug (2 Wire)	
A	YELLOW
B	—
C	WHITE / YELLOW
Splice Tap Wires	
Loose	BROWN
Loose	PURPLE
10-Position Plug	
A	YELLOW
B	GREEN
C	GREEN
D	RED
E	ORANGE
F	WHITE / YELLOW
G	PURPLE
H	BROWN
J	BLUE
K	LT BLUE

HEADLAMP WIRING – 8443 HARNESS KIT (2B/2D)

Harness Part #26638

Location	Wire Color
7-Pin Female Plug	
A	BROWN
B	YELLOW
C	PURPLE
D	PURPLE
E	GREEN
F	—
G	BLACK / ORANGE

7-Pin Male Plug	
A	BROWN
B	ORANGE
C	PURPLE
D	PURPLE
E	RED
F	—
G	BLACK / ORANGE

10-Position Plug (Tag #3)	
A	YELLOW
B	GREEN
C	—
D	RED
E	ORANGE
F	—
G	PURPLE
H	—
J	BLUE
K	LT BLUE

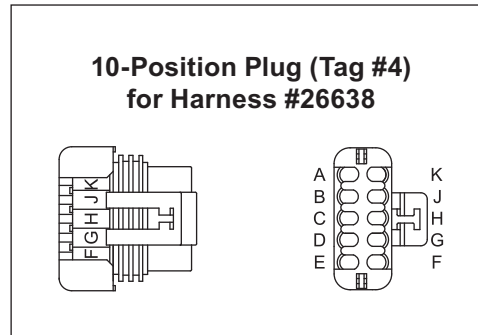
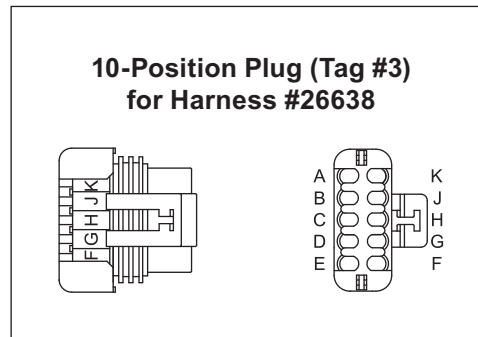
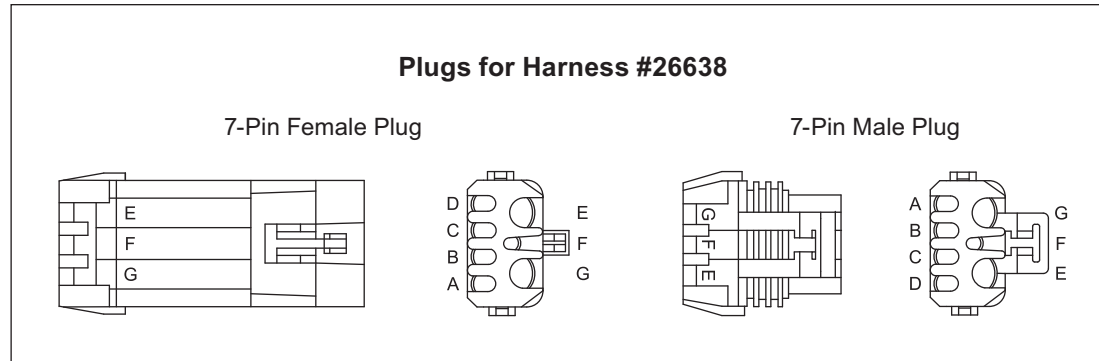

Harness Part #26638

Location	Wire Color
10-Position Plug (Tag #4)	
A	YELLOW
B	GREEN
C	—
D	—
E	—
F	—
G	PURPLE
H	BROWN
J	—
K	LT BLUE

HEADLAMP WIRING – 27480-1/8437-1 HARNESS KITS (HB-3/HB-4)

Harness Part #26360

Location	Wire Color
2-Key Female Plug	
A	LT BLUE
B	GREEN

2-Key Male Plug	
A	BLUE
B	RED

1-Key Female Plug	
A	BLUE
B	YELLOW

1-Key Male Plug	
A	BLUE
B	ORANGE

Splice Tap Wires	
Loose	PURPLE

10-Position Plug	
A	YELLOW
B	GREEN
C	—
D	RED
E	ORANGE
F	—
G	PURPLE
H	—
J	LT BLUE
K	BLUE

Plugs for Harnesses #26360 & #26361

2-Key Female Plug

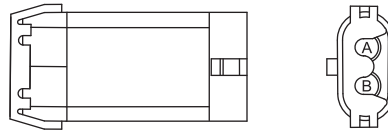

2-Key Male Plug

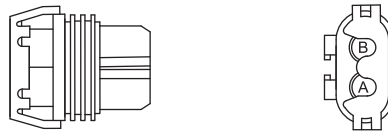

1-Key Female Plug

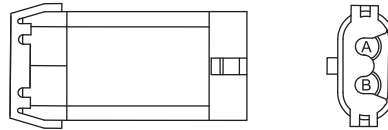

1-Key Male Plug

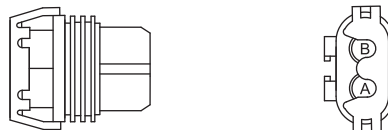

10-Position Plug for Harnesses #26360 & #26361

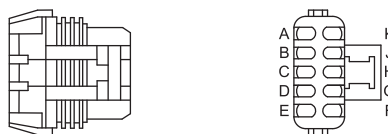

Harness Part #26361

Location	Wire Color
2-Key Female Plug	
A	LT BLUE
B	GREEN

2-Key Male Plug	
A	BLUE
B	RED

1-Key Female Plug	
A	BLUE
B	YELLOW

1-Key Male Plug	
A	BLUE
B	ORANGE

Splice Tap Wires	
Loose	BROWN
Loose	PURPLE
Loose	PINK*

10-Position Plug "B"	
A	YELLOW
B	GREEN
C	—
D	RED
E	ORANGE
F	PINK
G	PURPLE
H	BROWN
J	LT BLUE
K	BLUE

* Pink wire not used on 27480.

HEADLAMP WIRING – 27780/8438 HARNESS KITS (HB-3/HB-4)

Harness Part #26351

Location	Wire Color
2-Key Female Plug	
A	GREEN
B	BLUE

2-Key Male Plug	
A	RED
B	LT BLUE

1-Key Female Plug	
A	YELLOW
B	BLUE

1-Key Male Plug	
A	ORANGE
B	BLUE

Splice Tap Wires	
Loose	PURPLE
Loose	BROWN
Loose	PINK*

10-Position Plug	
A	YELLOW
B	GREEN
C	—
D	RED
E	ORANGE
F	PINK
G	PURPLE
H	BROWN
J	BLUE
K	LT BLUE

Plugs for Harnesses #26351 & #26352

2-Key Female Plug

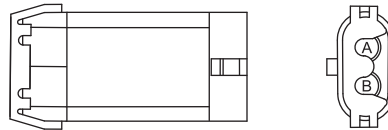

2-Key Male Plug

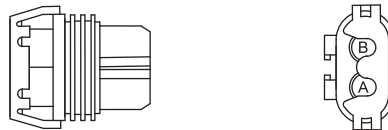

1-Key Female Plug

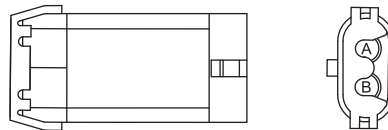

1-Key Male Plug

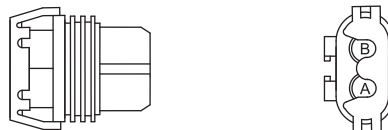

10-Position Plug for Harnesses #26351 & #26352

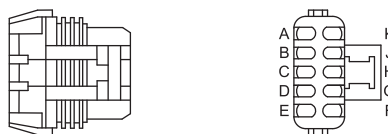

Harness Part #26352

Location	Wire Color
2-Key Female Plug	
A	GREEN
B	BLUE

2-Key Male Plug	
A	RED
B	LT BLUE

1-Key Female Plug	
A	YELLOW
B	BLUE

1-Key Male Plug	
A	ORANGE
B	BLUE

Splice Tap Wires	
Loose	PURPLE

10-Position Plug	
A	YELLOW
B	GREEN
C	—
D	RED
E	ORANGE
F	—
G	PURPLE
H	—
J	BLUE
K	LT BLUE

* Pink wire not used on 8438.

HEADLAMP WIRING – 27890 HARNESS KIT (2B/2D OR 1A/2A)

Harness Part #27885

Location	Wire Color
Female Plug	
A	YELLOW* / GREEN**
B	GREEN* / YELLOW**
C	BLUE
D	PURPLE
E	BROWN

* Rev. 0 ** Rev. 1

Male Plug	
A	RED
B	ORANGE
C	LT BLUE
D	PURPLE
E	BROWN

10-Position Plug	
A	GREEN* YELLOW**
B	YELLOW* GREEN**
C	—
D	RED
E	ORANGE
F	—
G	PURPLE
H	BROWN
J	BLUE
K	LT BLUE

* Rev. 0 ** Rev. 1

Plugs for Harnesses #27885 and #27886

Female Plug



Male Plug



10-Position Plug for Harnesses #27885 and #27886

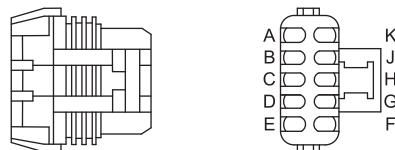

Harness Part #27886

Location	Wire Color
Female Plug	
A	YELLOW* / GREEN**
B	GREEN* / YELLOW**
C	BLUE
D	PURPLE
E	BROWN

* Rev. 0 ** Rev. 1

Male Plug	
A	RED
B	ORANGE
C	LT BLUE
D	PURPLE
E	BROWN

10-Position Plug	
A	GREEN* YELLOW**
B	YELLOW* GREEN**
C	—
D	RED
E	ORANGE
F	—
G	PURPLE
H	—
J	BLUE
K	LT BLUE

* Rev. 0 ** Rev. 1

HEADLAMP WIRING – 28028 HARNESS KIT (HB-3/HB-4)

Harness Part #28030

Location	Wire Color
Female Plug	
A	GREEN
B	YELLOW
C	LT BLUE
D	BLUE

Male Plug	
A	RED
B	ORANGE
C	BLUE
D	BLUE

Splice Tap Wires	
Loose	PURPLE

10-Position Plug	
A	YELLOW
B	GREEN
C	—
D	RED
E	ORANGE
F	—
G	PURPLE
H	—
J	LT BLUE
K	BLUE

Plugs for Harnesses #28030 and #28032

Female Plug

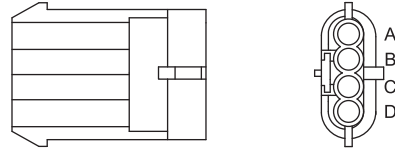

Male Plug

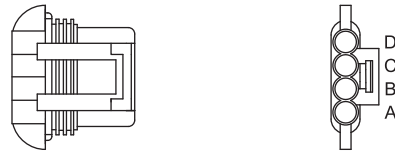

10-Position Plug for Harnesses #28030 and #28032

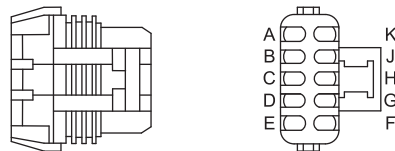

Harness Part #28032

Location	Wire Color
Female Plug	
A	GREEN
B	YELLOW
C	LT BLUE
D	BLUE

Male Plug	
A	RED
B	ORANGE
C	BLUE
D	BLUE

Splice Tap Wires	
Loose	PURPLE
Loose	BROWN

10-Position Plug	
A	YELLOW
B	GREEN
C	—
D	RED
E	ORANGE
F	—
G	PURPLE
H	BROWN
J	LT BLUE
K	BLUE

HEADLAMP WIRING – 28400 HARNESS KIT (H13)

Harness Part #28242*

Location	Wire Color
Female Plug	
A	ORANGE
B	LT BLUE
C	RED

Male Plug	
A	YELLOW
B	BLUE
C	GREEN

Splice Tap Wires	
Loose	PURPLE

*Rev. 3 and Higher

10-Position Plug	
A	YELLOW
B	GREEN
C	—
D	RED
E	ORANGE
F	—
G	PURPLE
H	—
J	BLUE
K	LT BLUE

Plugs for Harnesses #28242 and #28244

Female Plug

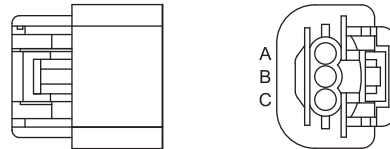

Male Plug

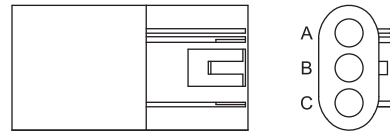

10-Position Plug for Harnesses #28242 and #28244

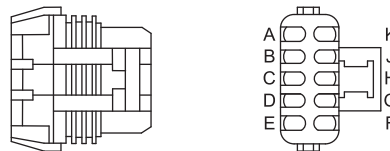

Harness Part #28244*

Location	Wire Color
Female Plug	
A	ORANGE
B	LT BLUE
C	RED

Male Plug	
A	YELLOW
B	BLUE
C	GREEN

Splice Tap Wires	
Loose	PURPLE
Loose	BROWN

*Rev. 3 and Higher

10-Position Plug	
A	YELLOW
B	GREEN
C	—
D	RED
E	ORANGE
F	—
G	PURPLE
H	BROWN
J	BLUE
K	LT BLUE

This page intentionally left blank.

RELAY SYSTEM – HEADLAMP INDEX

Vehicle(s)	Year(s)	Headlamp Type	Headlamp Harness Part #	DRLs	Page No.
Chevrolet-GMC					
Silverado	'03	HB-3/HB-4	64075	Yes	86
Silverado, Sierra (Low Side Drive System)	'99-'02	HB-3/HB-4	26071	Yes	66
GM C4500, 5500	'03	2B, 1A/2A**	64126	Yes	59
S10/S15 Blazer, Jimmy and Pickup	'98	HB-3/HB-4	62914	Yes	80
All (except S10/S15 Blazer, Jimmy, and Pickup)	'98	2B	61546	Yes	59
		HB-3/HB-4	61716	Yes	60
K1500, K2500, K3500, C2500, C3500 Pickups/Chassis Cabs, Blazer, Jimmy, Tahoe, Yukon	'96,'97	2B	61546	Yes	59
		HB-3/HB-4	61716	Yes	60
S10/S15 Blazer, Jimmy and Pickup; Sonoma	'83-'97	2B	61546	No	56
		2E	62536*	Yes	77
			61576	No	61
		HB-3/HB-4	61586	Yes	78
			61716	No	57
Suburban, Blazer, Jimmy, Tahoe, Yukon	'92-'95	2B	61556	Yes	77
			61546	No	56
		HB-3/HB-4	61586	Yes	78
			61716	No	57
K2500, K3500, K3500 HD Chassis Cabs	'90-'95	2B	61556	Yes	77
			61546	No	56
		HB-3/HB-4	61586	Yes	78
			61716	No	57
		LF/UF	61581 modified	Yes	79
			61581	No	57

* Early GM applications used 61576 and 61556 harnesses spliced together.
 ** DRL kit not required. Refer to relay connections only.

Vehicle(s)	Year(s)	Headlamp Type	Headlamp Harness Part #	DRLs	Page No.
Chevrolet-GMC					
K1500, K2500, K3500, C2500, C3500 Pickups	'88-'95	2B	61556	Yes	77
			61546	No	56
		HB3/HB4	61586	Yes	78
			61716	No	57
		LF/UF	61581 modified	Yes	79
			61581	No	57
K2500, K3500, K3500 HD, R20 2WD Chassis Cabs	'81-'89	1A/2A	61566	No	58
		2B	61556	Yes	77
			61546	No	56
Suburban, Blazer, Jimmy, R30 2WD, V30 4x4	'81-'91	1A/2A	61566	No	58
			61556	Yes	77
		2B	61546	No	56
			LF/UF	61581 modified	Yes
		61581		No	57
K1500, K2500, K3500, C2500, C3500, V10, V20 Pickups	'81-'87	1A/2A	61566	No	58
		2B	61556	Yes	77
			61546	No	56
Jeep					
Cherokee, Wagoneer, Pioneer	'84-'01	2B	61731	Yes	62
			61731	No	61
		LF/UF	61581	No	57
Wrangler	'86-'03	2B	61731	Yes	62
Comanche	'86-'93			No	61

See Isolation Module Section for 2004 and newer applications.

RELAY SYSTEM – HEADLAMP INDEX

Vehicle(s)	Year(s)	Headlamp Type	Headlamp Harness Part #	DRLs	Page No.
Dodge					
Dakota 4x4	'87-'98	HB-1	62526	No	61
				Yes	62
		HB-5	61591	No	56
				Yes	59
		2E	61576	No	61
				Yes	62
Dakota	'01-'03	HB-5	63413	No	67
Durango	'01-'03			Rev 1-3	Yes
Dakota/Durango (Low Side Drive System)	'99-'00	HB-5	26027	Yes	82
				No	64
Ram 1500 ('99-'01) Ram 2500, 3500 (Low Side Drive)	'99-'02	HB-1	26009	Yes	81
			26009	No	63
		HB-1/HB-5	26027	Yes	83
			26027	No	65
W100/150/200/250/300/350/ 350 4x4; RamCharger/ TrailDuster 4x4	'72-'93	2B/2D	61731	No	61
				Yes	62
		1A/2A	61566	No	58
Ram 1500, 2500, 3500 Pickup & Chassis Cab 4x2/4x4	'94-'98	HB-1	62526	No	61
				Yes	62
Ram 1500 REV 3 only	'02	HB-5	63413 Rev 3 only	No	68
				Yes	69
Ram 1500/2500/3500	'03	HB-5	63413 Rev 3 & Higher	No	84
				Yes	85

See Isolation Module Section for 2004 and newer applications.

Vehicle(s)	Year(s)	Headlamp Type	Headlamp Harness Part #	DRLs	Page No.
Ford (Mazda)					
F-150/250/350/ Super Duty HD/4x2/4x4 F-150 ('97-Present) F-250 LD ('97-'98)	'80-'91	HB-1	61571	No	56
				Yes	59
		2B	61546	No	56
				Yes	59
	'92-'98	HB-5	61591	No	56
				Yes	59
'99 Super Duty Series F-250HD/350/450/550	'99-'03	HB-5	61591	No	56
				Yes	59
		2B	61546	No	56
				Yes	59
Bronco II ('83-'90), Bronco Full Size ('80-'93), Ranger ('83-'96), B4000 Mazda ('94), Explorer/Navajo (Mazda) ('91-'94) (HB-1 only)	'80-'96	HB-5	61591	No	56
				Yes	59
		HB-1	61571	No	56
				Yes	59
		2B	61546	No	56
				Yes	59
Toyota					
4-Runner 4x4	'84-'95	HB-1	61571 (Qty 2)	No	76
				Yes	74
		2B	61556	No	75
			61546 (Qty 2)	Yes	74
Tacoma Pickup 4x4	'95-'03	2B	61556	No	75
			61556	Yes	77
Pickup 4x4	'84-'95	2B	61556	No	75
			61546 (Qty 2)	Yes	74

RELAY SYSTEM – ELECTRICAL CONNECTORS

Harness Connectors – Relay System

Headlamp Relay Terminal Locations

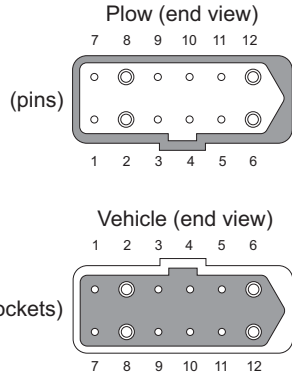
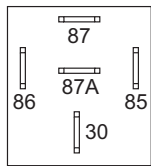

NOTE: The 7-, 9- and 12-pin harness connector pin #s are embossed in the molded plug.

Pin #	Wire Color			Control Function
	7-Pin	9-Pin	12-Pin	
1	—	White/Yellow	White/Yellow	Valve S1(2W)
2	Black ^a	Black ^a	Black	Low Beam 9/12-Pin Rt
3	—	Lt Green	Lt Green	Valve S2(3W)
4	—	Lt Blue	Lt Blue	Valve S3(4W)
5	Black/Orange ^c	Black/Orange ^{c,d}	Black/Orange ^{c,d}	Ground
6	White	White	White	High Beam
7	—	—	Black/White	Low Beam 12-Pin Lt
8	—	—	Dk Blue/Orange	Gnd Low Beam 12-Pin Rt
9	Gray	Gray	Gray	Left Directional
10	Purple	Purple	Purple	Right Directional
11	Brown	Brown	Brown	Parking Lights
12	Orange/Black ^b	—	Lt Blue/Orange	Gnd Low Beam 12-Pin Lt

^aLeft and Right Sides.

^b7-Pin System—Main Ground.

^cGround for Headlight Relays Only.

^dOn Early Revision Harnesses, Black/Orange Wire is Ground for Motor Relay, Control and Headlight Relays.

Straight Blade Control Connectors

Control Side (end view)

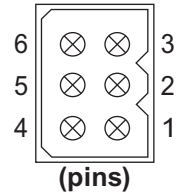

Pin #	Wire Color
1	White
2	Green
3	Brown
4	Black
5	Blue
6	Red

Vehicle Side (end view)

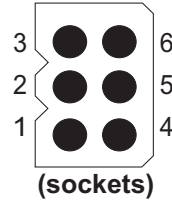

Pin #	Wire Color	Control Function
1	Red	+12V
2	Lt Green	S2 (3W)
3	Orange/Black	Ground
4	Brown/Red	Motor Relay
5	Lt Blue	S3 (4W)
6	White/Yellow	S1 (2W)

MVP® Blade Connectors

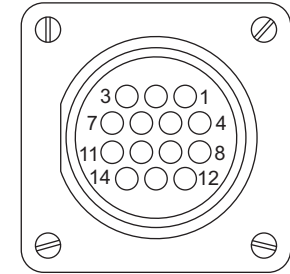

(Front View)

Pin #	Wire Color
1	Lt Blue w/Orange Stripe
2	Blue w/Orange Stripe
3	Black w/White Stripe
4	Lt Green
5	Lt Blue
6	White w/Yellow Stripe
7	Brown w/Red Stripe
8	Red
9	Orange w/Black Stripe
10	Brown w/Green Stripe

MVP Blade to Straight Blade Adapter Kit PN 66760K

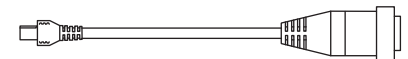

7-PIN HARNESS

PLOW SIDE

HEADLAMP KIT: 7 PIN

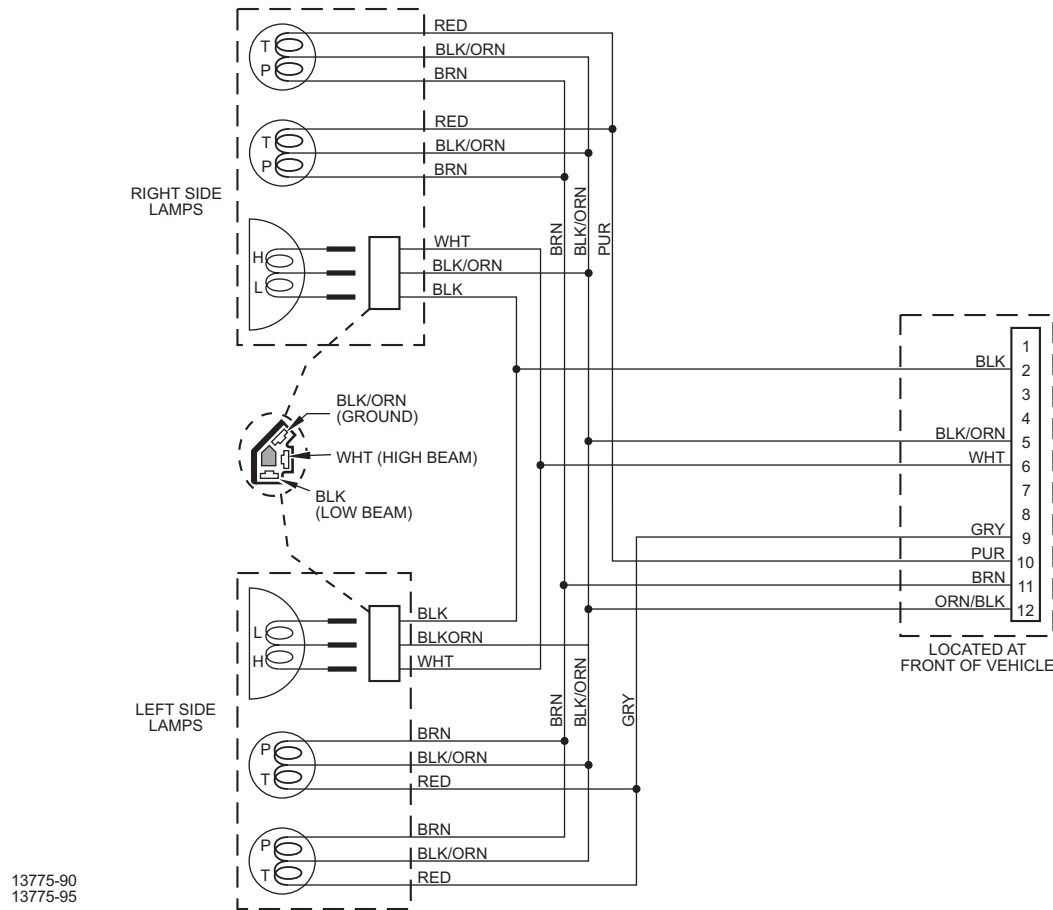

7-PIN HARNESS

Headlamp Relay
Terminal Locations

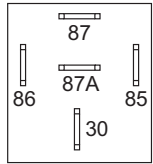

VEHICLE SIDE

HEADLAMP KIT: 7 PIN
 HARNESS TYPE: A
 HEADLAMPS: HB1/HB5
 DRLs: NO

For other headlamp configurations using the 7-pin harness, use the appropriate 9-pin vehicle schematic.

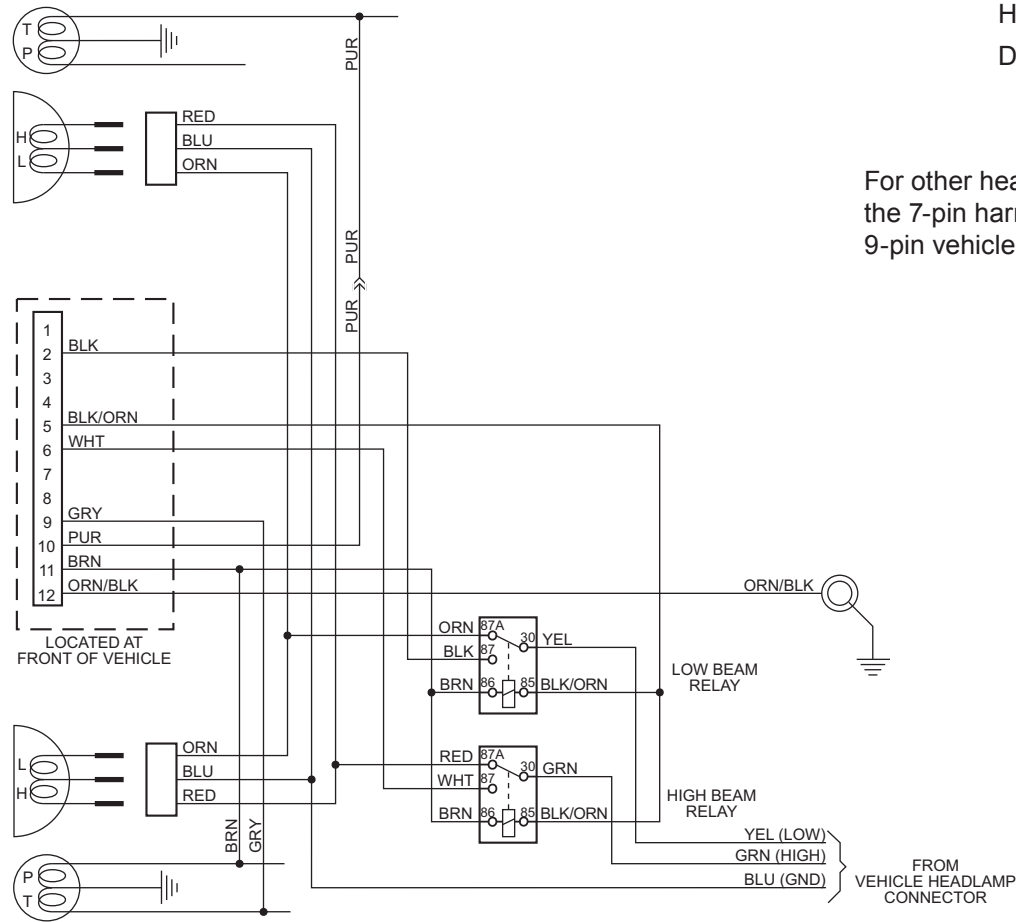

13775-95

NOTE: All relays are shown in the de-energized state.

7-PIN HARNESS

Headlamp Relay
Terminal Locations

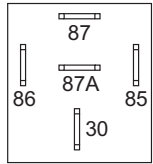

VEHICLE SIDE

HEADLAMP KIT: 7 PIN
 HARNESS TYPE: A
 HEADLAMPS: HB1/HB5
 DRLs: YES

For other headlamp configurations using the 7-pin harness, use the appropriate 9-pin vehicle schematic.

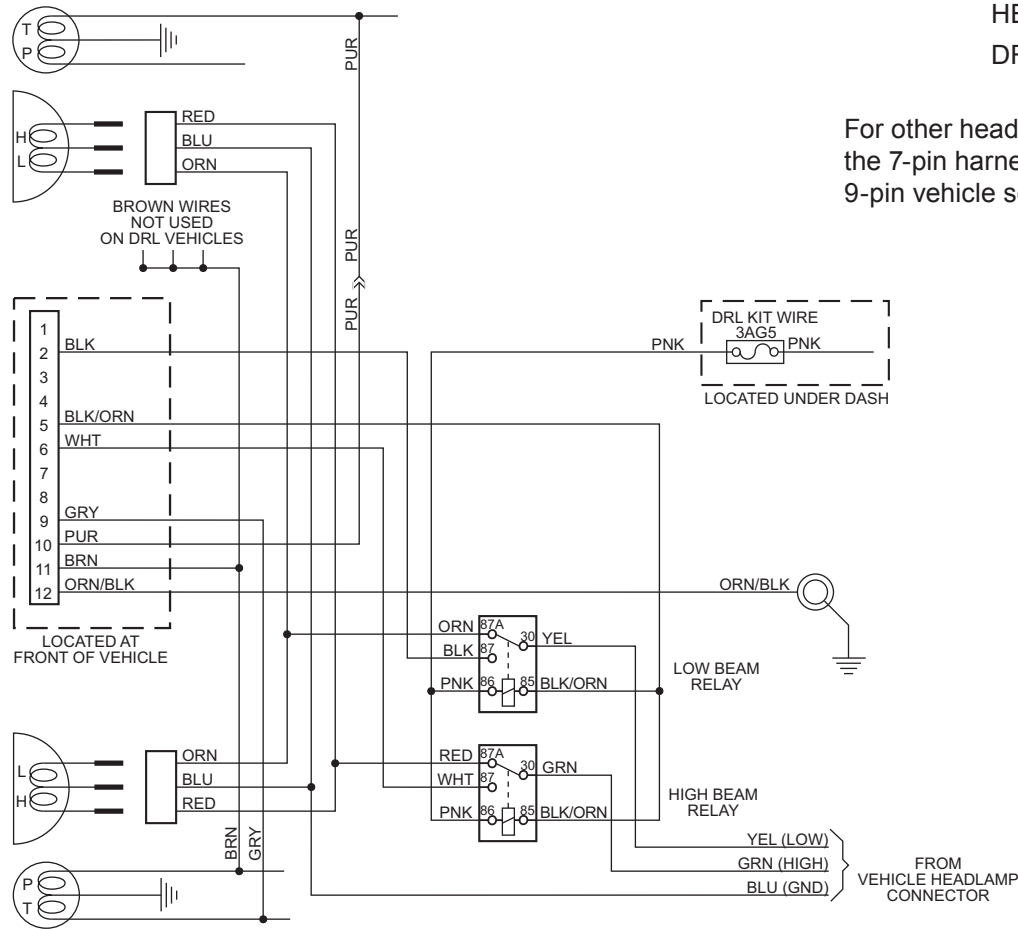

NOTE: All relays are shown in the de-energized state.

ELECTRICAL SCHEMATIC – 9-PIN VEHICLE HARNESS – REVISION 10 AND LATER

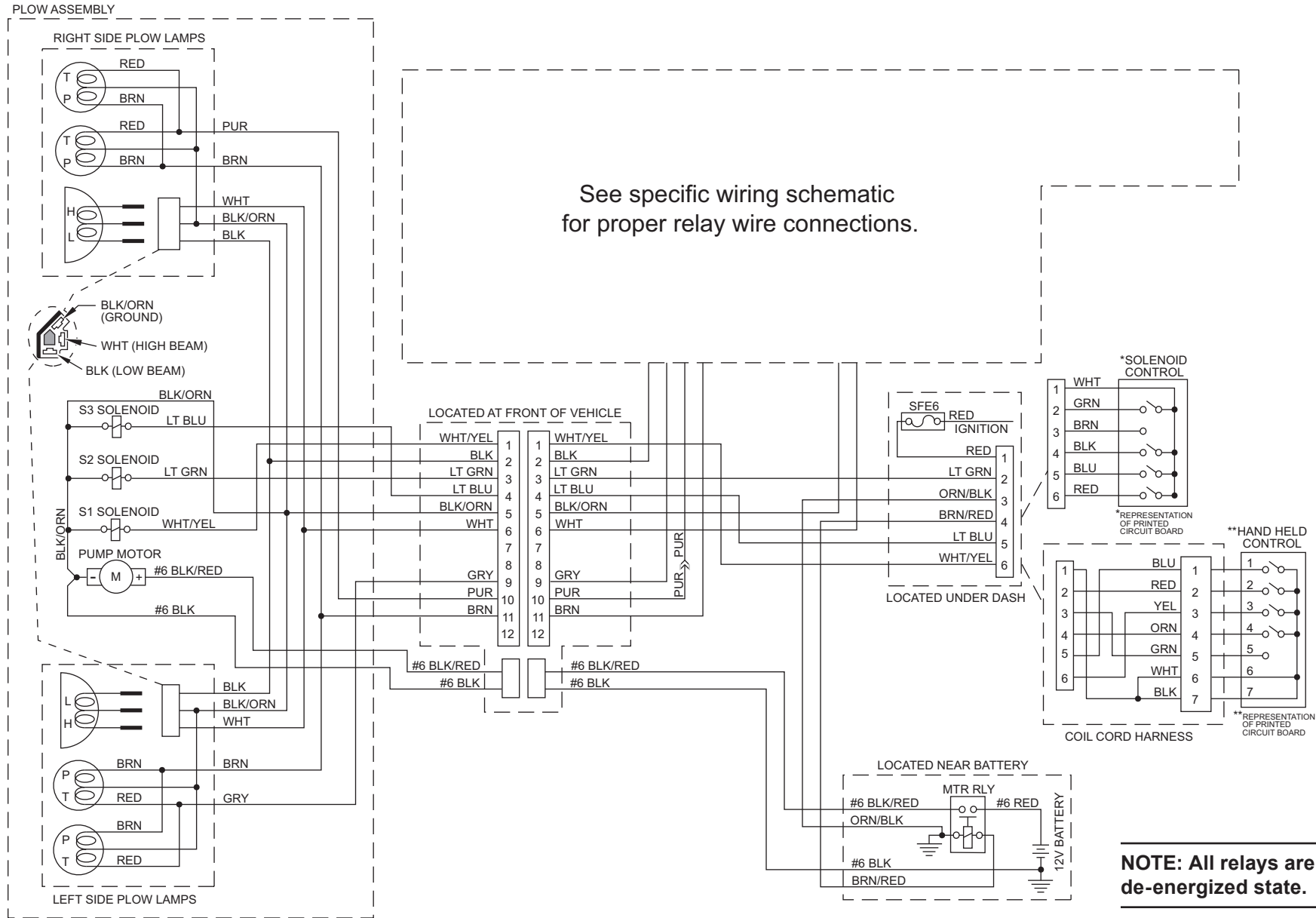

NOTE: All relays are shown in the de-energized state.

ELECTRICAL SCHEMATIC – 9-PIN VEHICLE HARNESS – REVISION 1-9

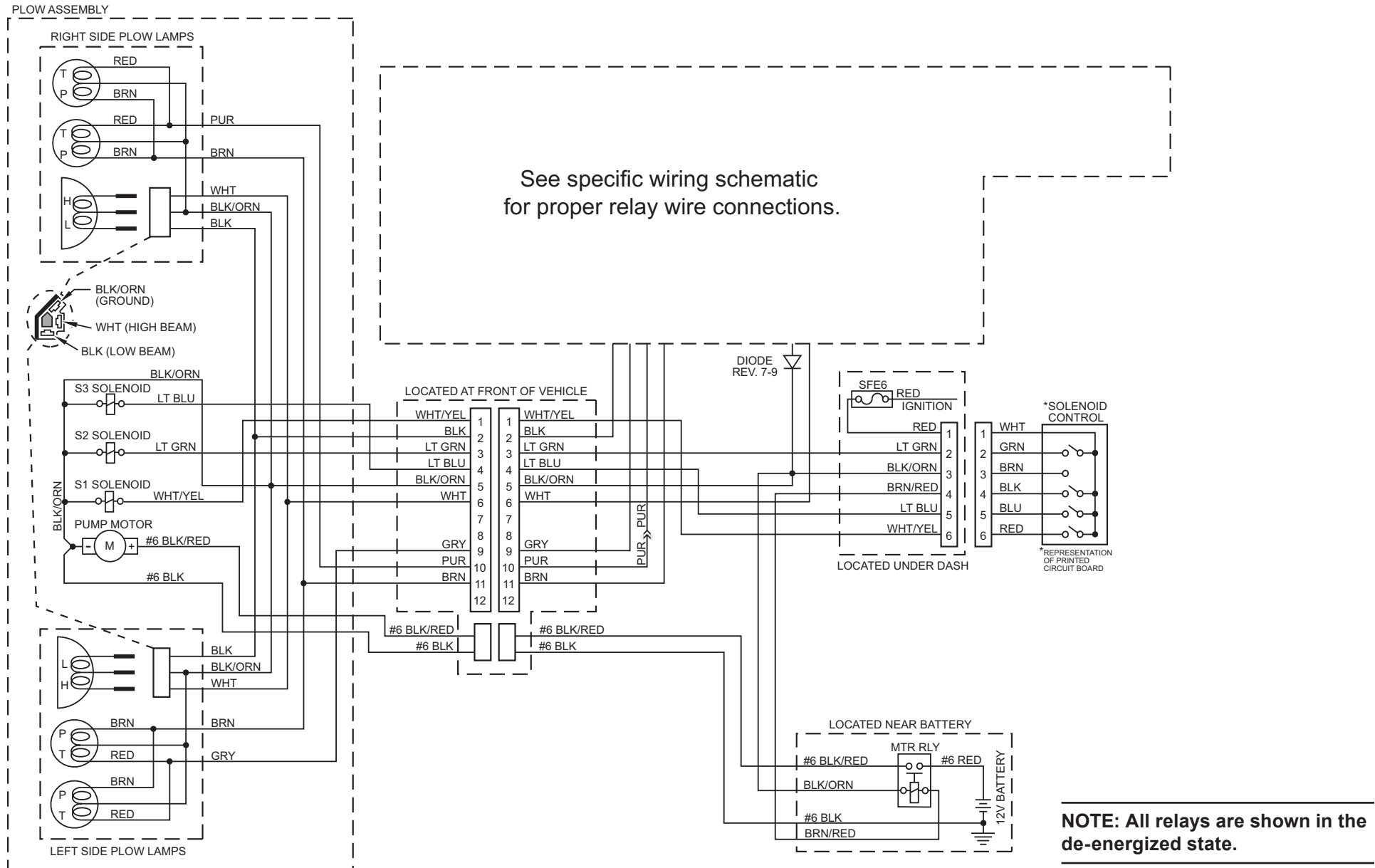

9-PIN HARNESS

PLOW SIDE

HEADLAMP KIT: 9 PIN

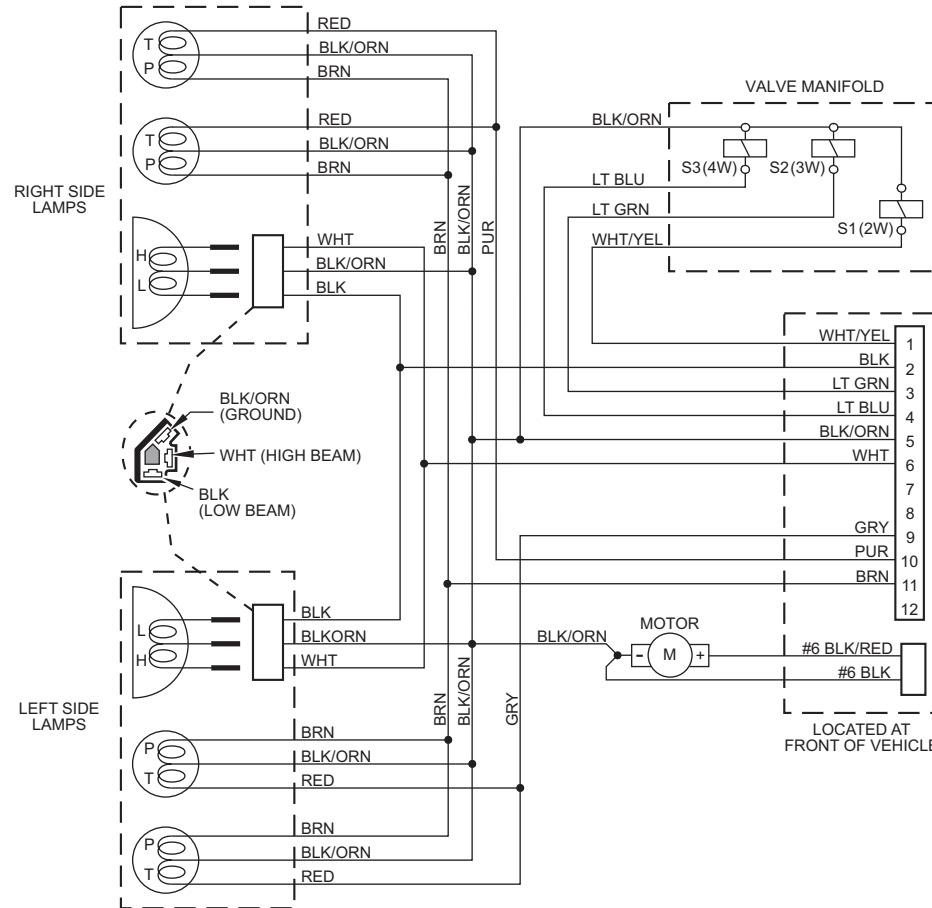

9-PIN HARNESS

Headlamp Relay
Terminal Locations

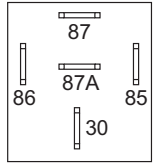

VEHICLE SIDE

HEADLAMP KIT: 9 PIN
 HARNESS TYPE: A
 HEADLAMPS: 2B/2D
 HB1/HB5
 DRLs: NO

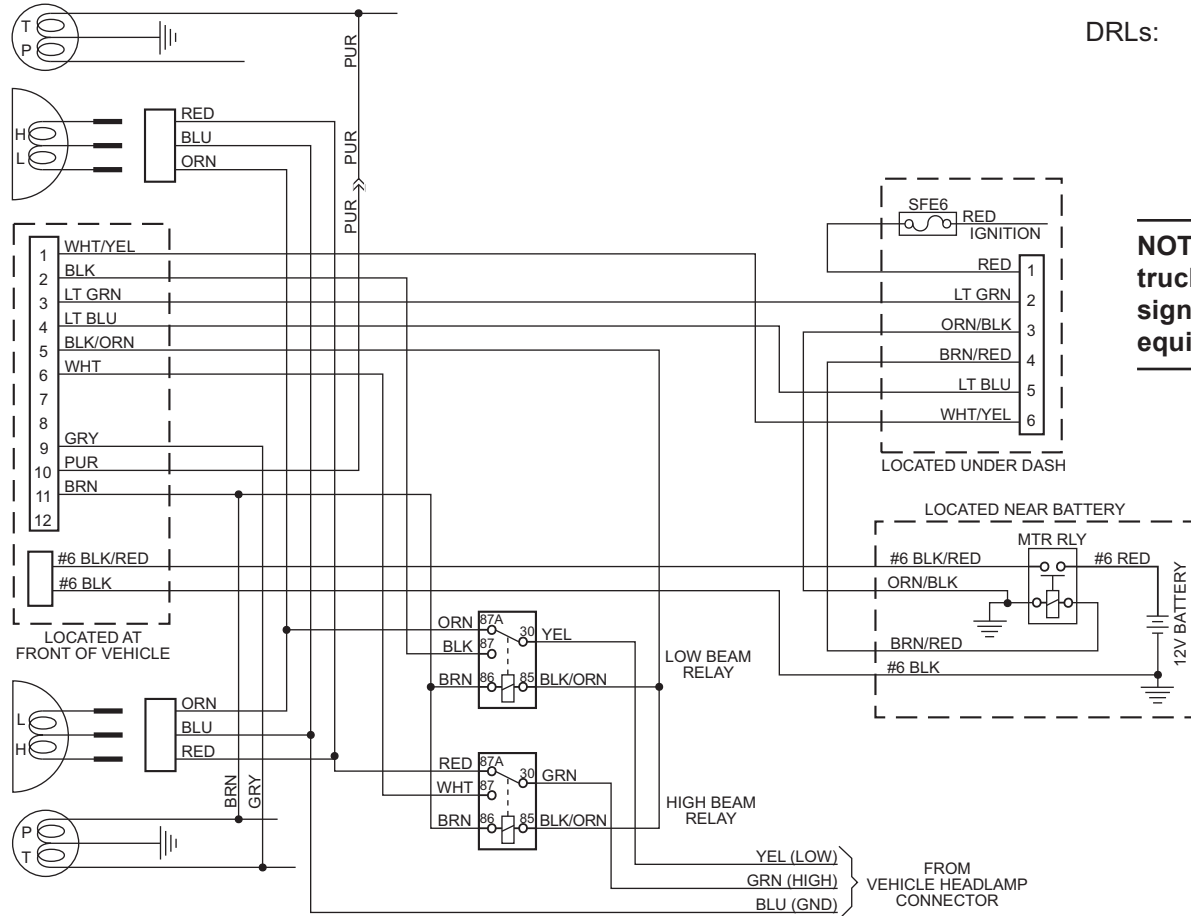

NOTE: All 1997 and later Ford trucks require Kit #61185 for turn signals and cab marker lights if equipped.

NOTE: All relays are shown in the de-energized state.

9-PIN HARNESS

Headlamp Relay
Terminal Locations

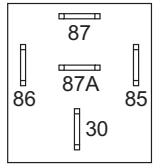

VEHICLE SIDE

HEADLAMP KIT: 9 PIN
 HARNESS TYPE: A
 HEADLAMPS: HB3/HB4
 LF/UF
 DRLs: NO

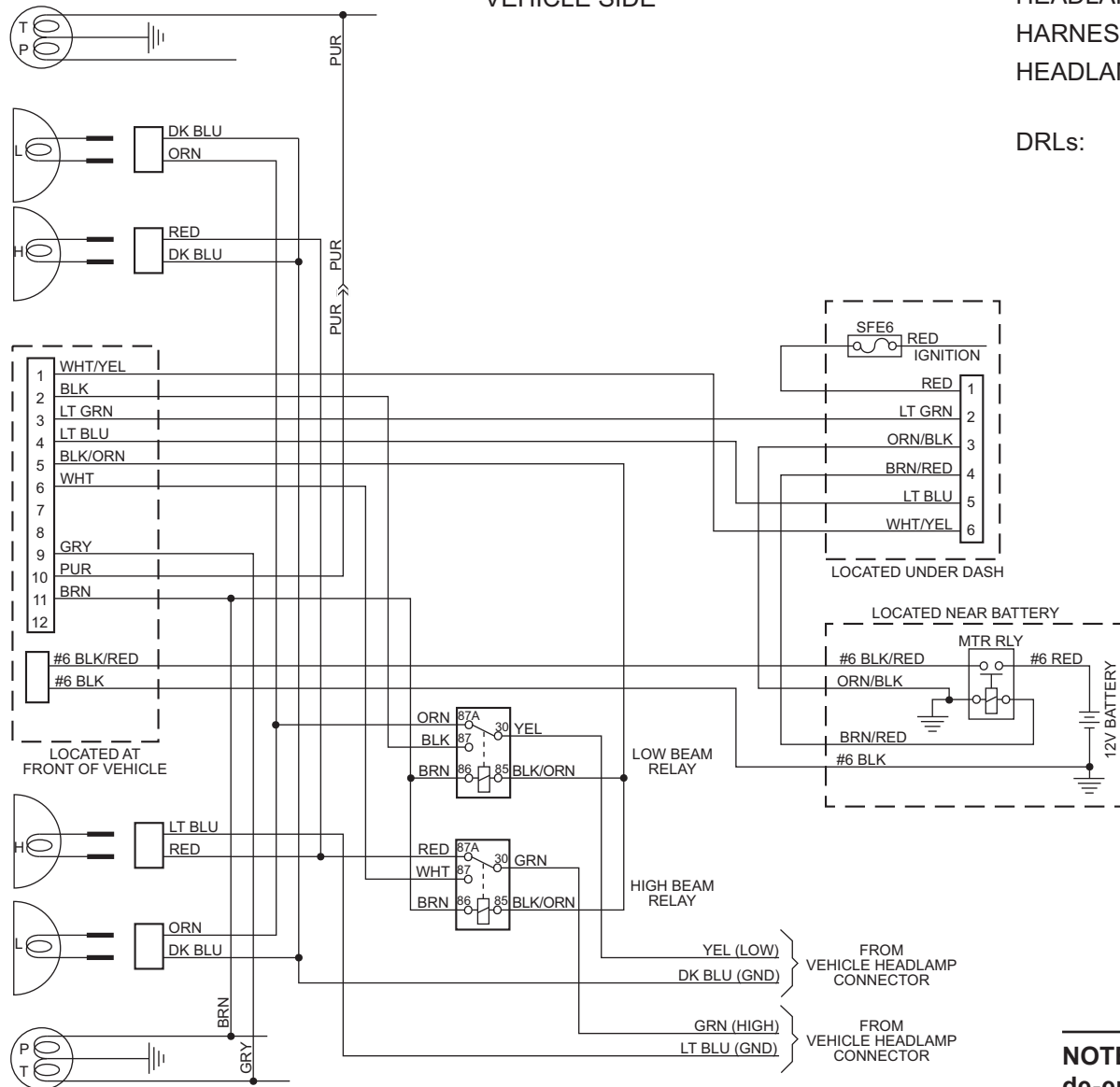

13637-97

NOTE: All relays are shown in the de-energized state.

9-PIN HARNESS

Headlamp Relay
Terminal Locations

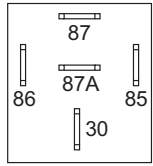

VEHICLE SIDE

HEADLAMP KIT: 9 PIN
HARNESS TYPE: A
HEADLAMPS: 1A/2A
DRLs: NO

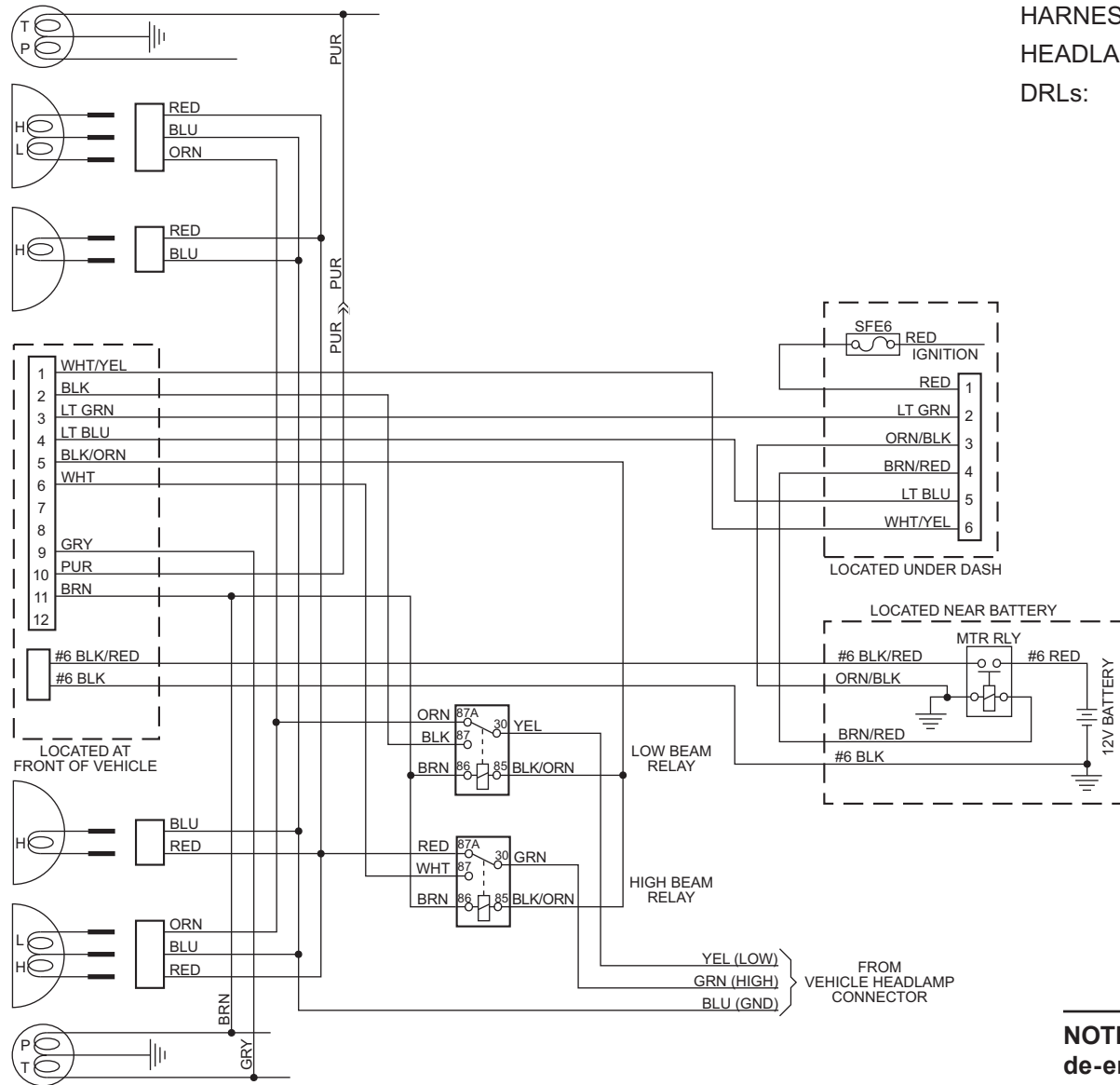

13597-97

NOTE: All relays are shown in the de-energized state.

9-PIN HARNESS

Headlamp Relay Terminal Locations

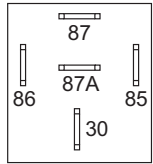

VEHICLE SIDE

HEADLAMP KIT: 9 PIN
 HARNESS TYPE: A
 HEADLAMPS: 2B/2D
 HB1/HB5
 DRLs: YES

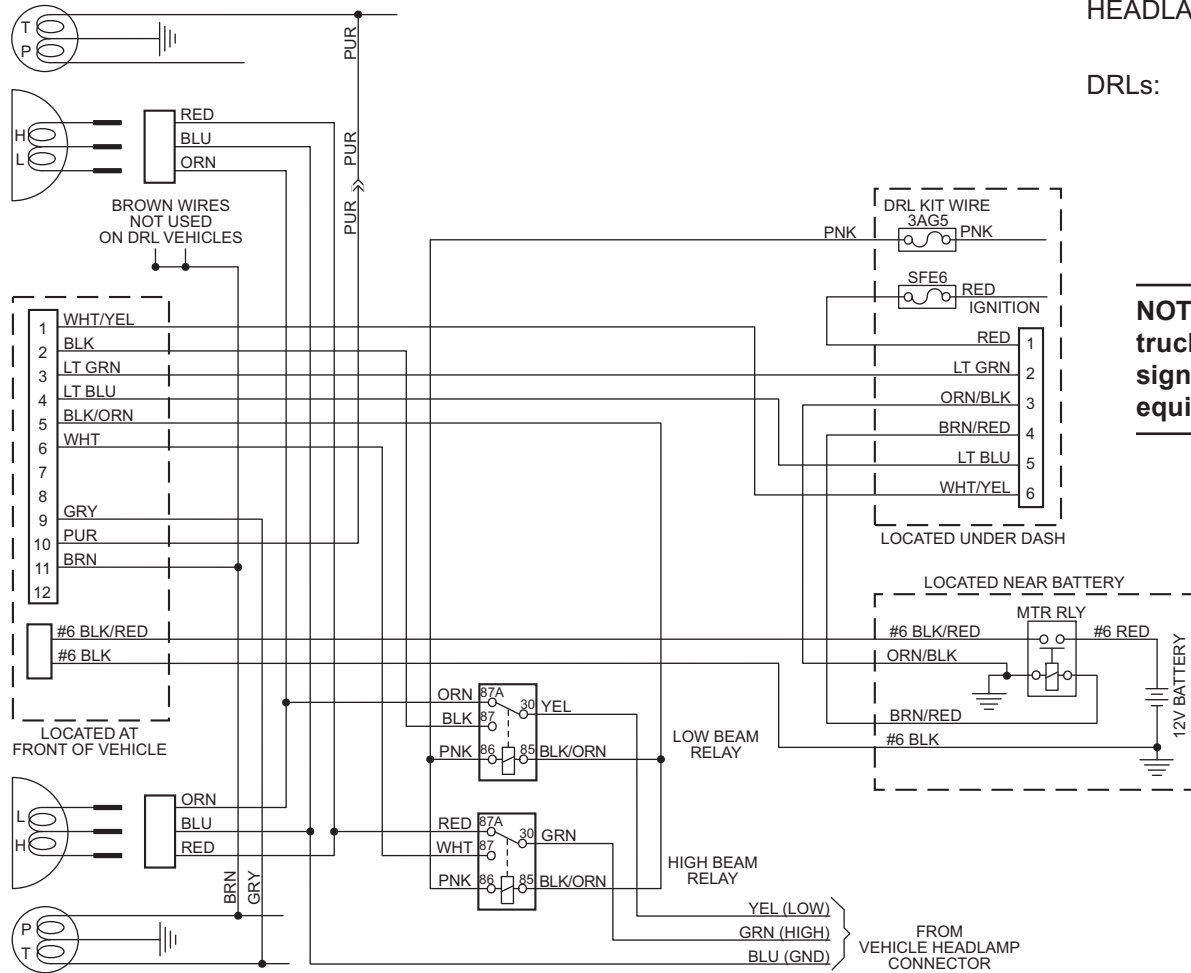

13606-93

NOTE: All 1997 and later Ford trucks require Kit #61185 for turn signals and cab marker lights if equipped.

NOTE: All relays are shown in the de-energized state.

9-PIN HARNESS

Headlamp Relay
Terminal Locations

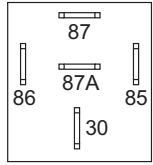

VEHICLE SIDE

HEADLAMP KIT: 9 PIN
HARNESS TYPE: A
HEADLAMPS: HB3/HB4
DRLs: YES

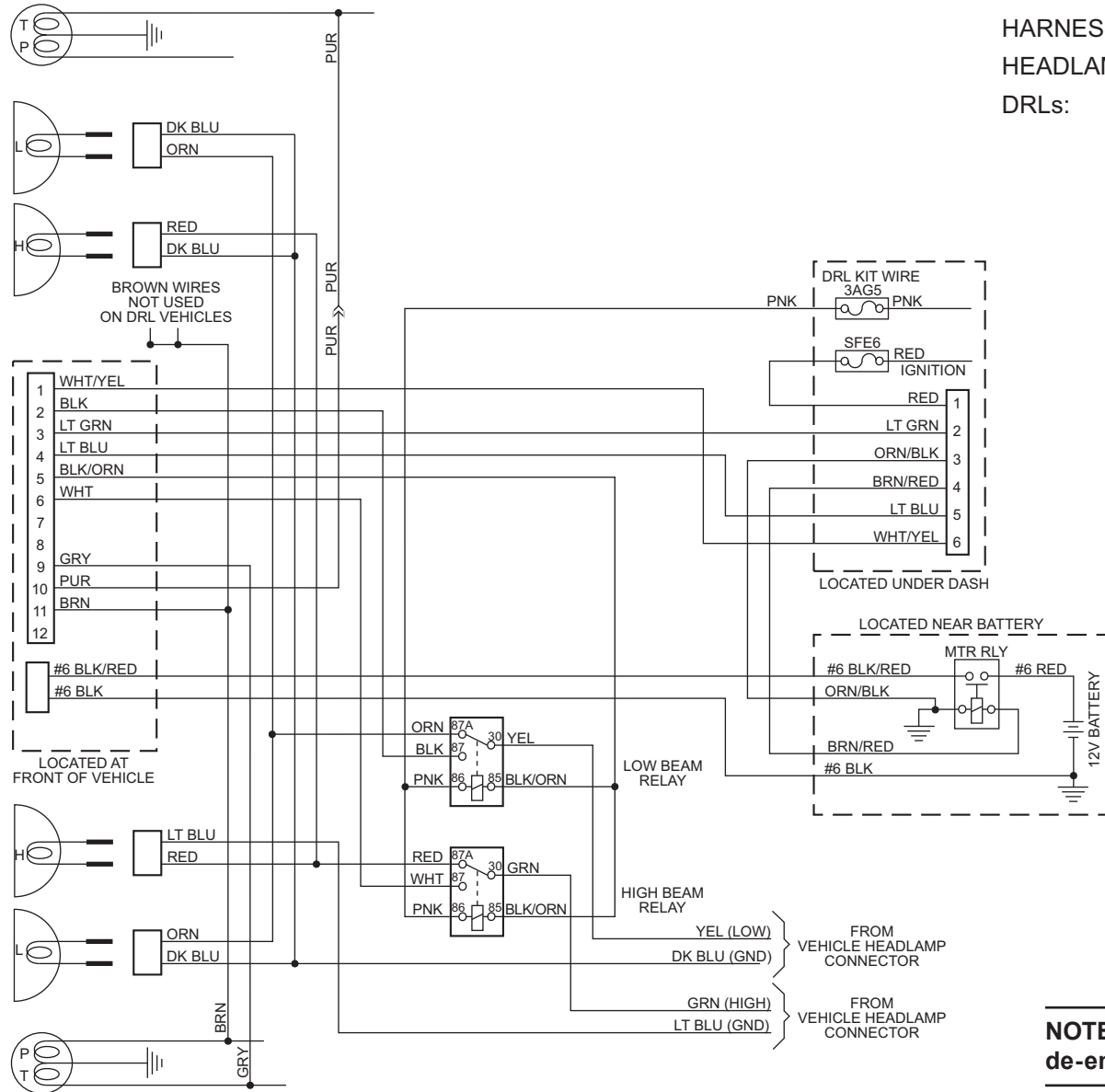

13637-92

9-PIN HARNESS

Headlamp Relay
Terminal Locations

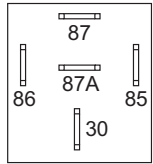

VEHICLE SIDE

HEADLAMP KIT: 9 PIN
 HARNESS TYPE: C
 HEADLAMPS: 2B/2D
 2E
 HB1
 DRLs: NO

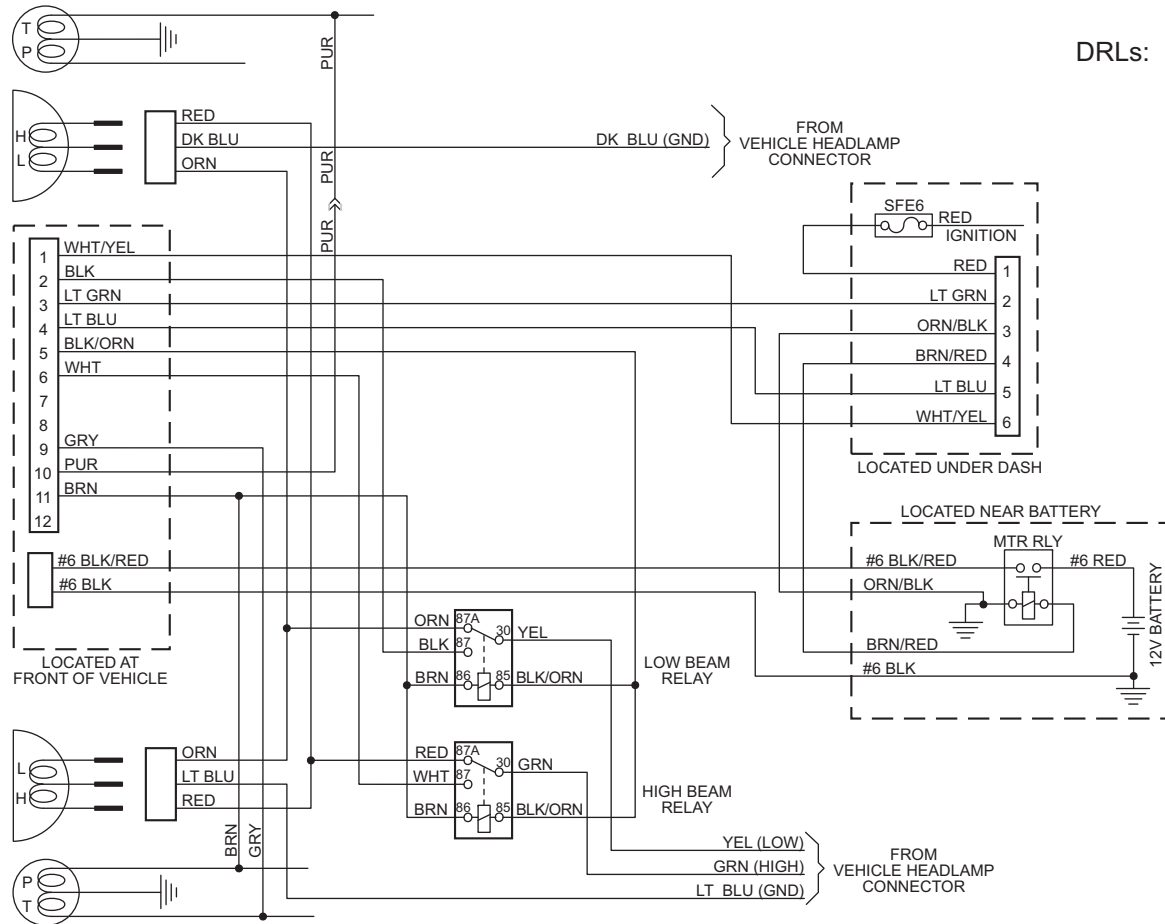

13607-98
63103-91

NOTE: All relays are shown in the de-energized state.

9-PIN HARNESS

Headlamp Relay
Terminal Locations

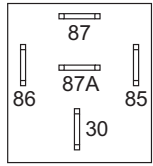

VEHICLE SIDE

HEADLAMP KIT: 9 PIN
 HARNESS TYPE: C
 HEADLAMPS: 2B/2D
 2E
 HB1
 DRLs: YES

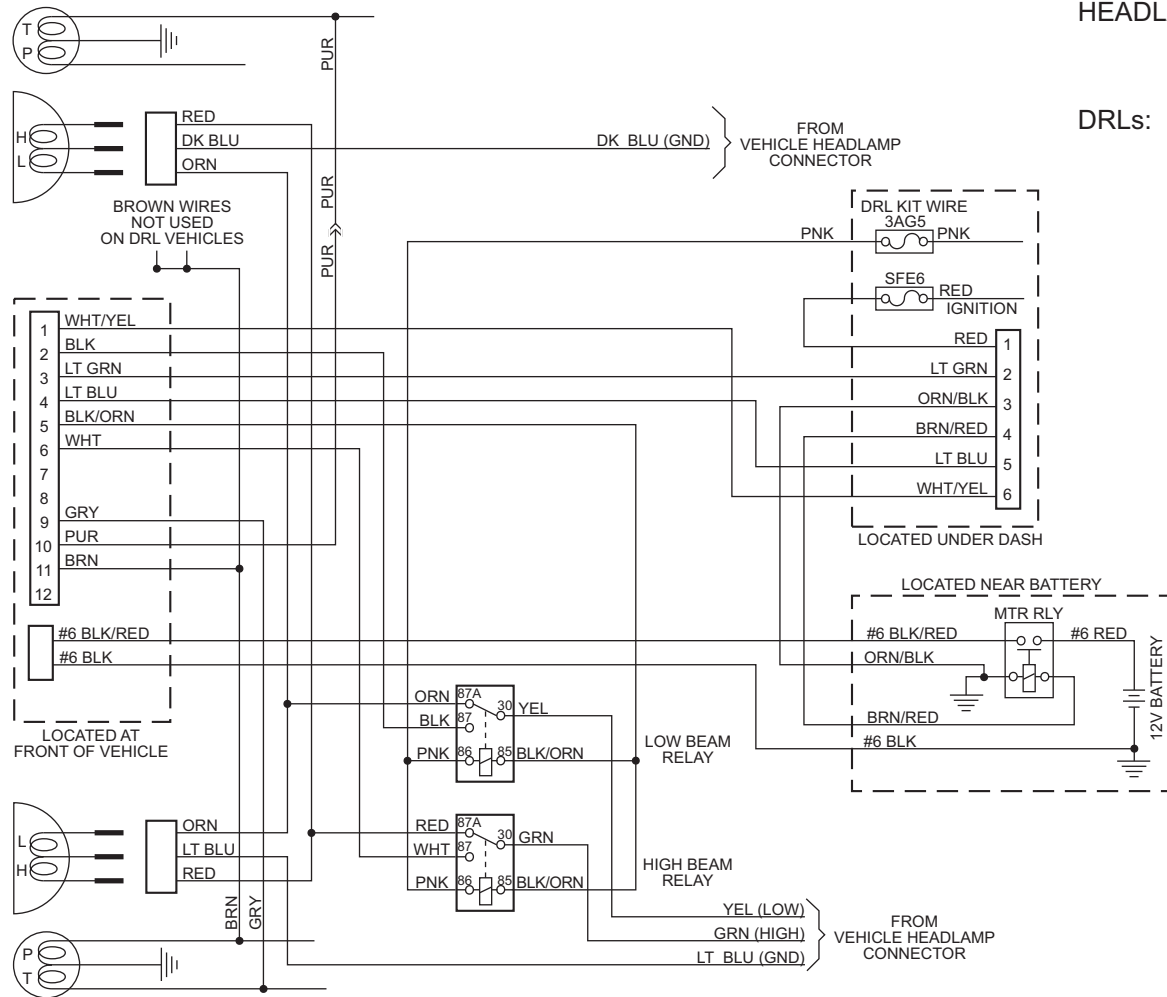

13607-92
63103-92

NOTE: All relays are shown in the de-energized state.

9-PIN HARNESS

Headlamp Relay
Terminal Locations

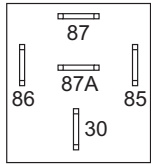

VEHICLE SIDE

HEADLAMP KIT: 9 PIN
HARNESS TYPE: F
HEADLAMPS: HB1
DRLs: NO

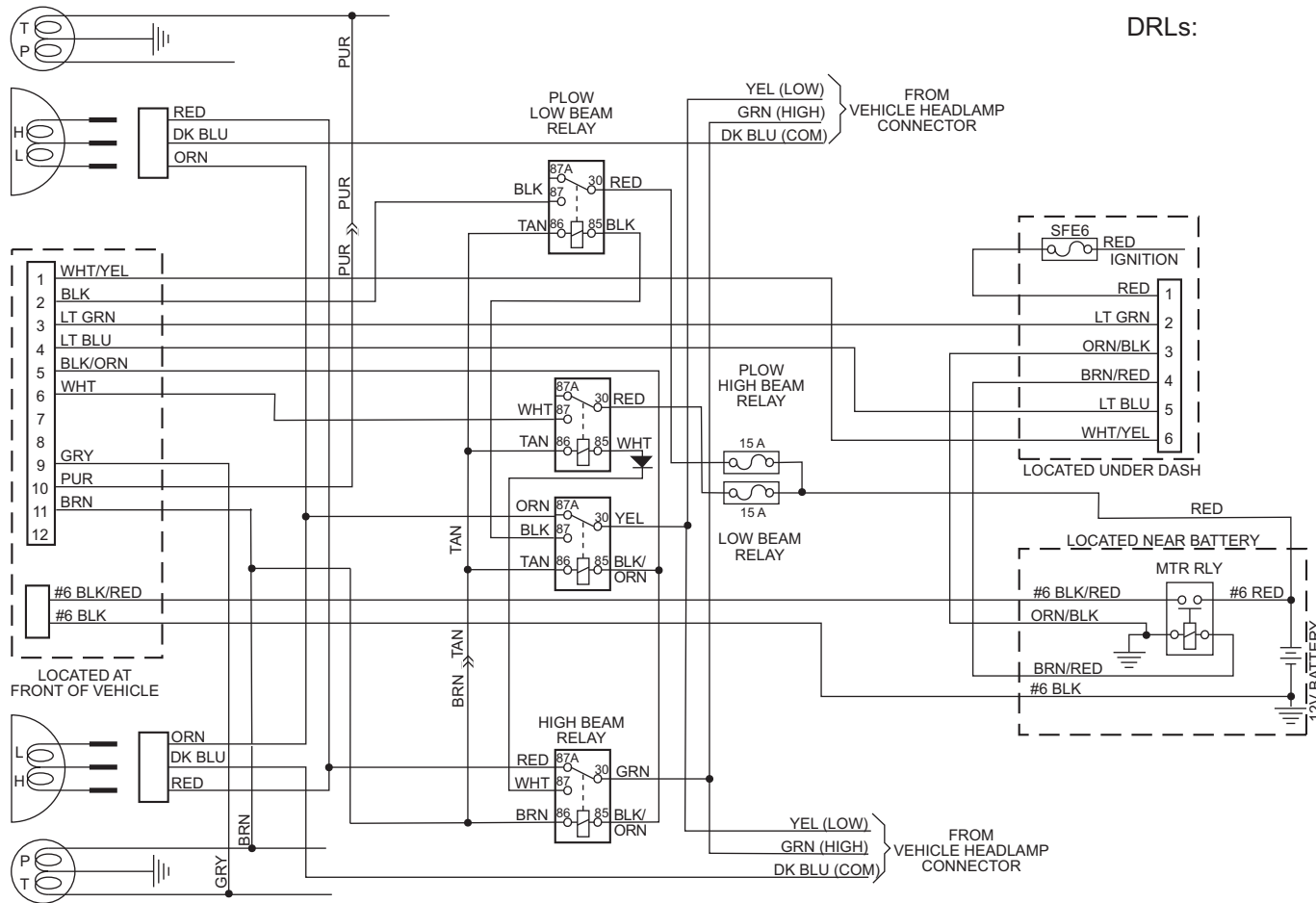

13607-98
63103-91

NOTE: All relays are shown in the de-energized state.

9-PIN HARNESS

Headlamp Relay Terminal Locations

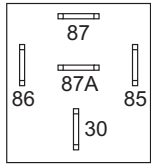

VEHICLE SIDE

HEADLAMP KIT: 9 PIN
 HARNESS TYPE: F
 HEADLAMPS: HB5
 DRLs: NO

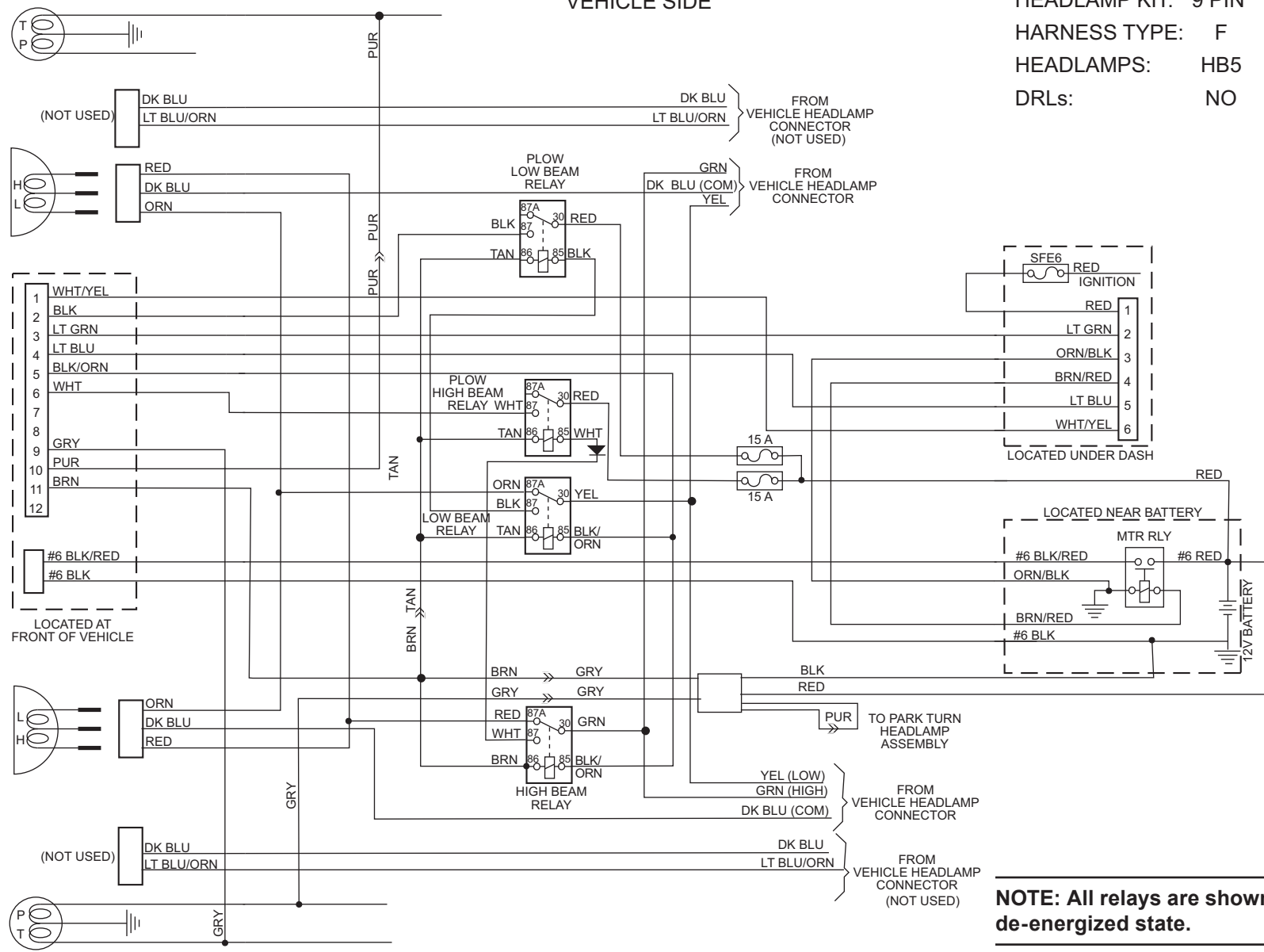

NOTE: All relays are shown in the de-energized state.

13607-98
63103-91

9-PIN HARNESS

Headlamp Relay Terminal Locations

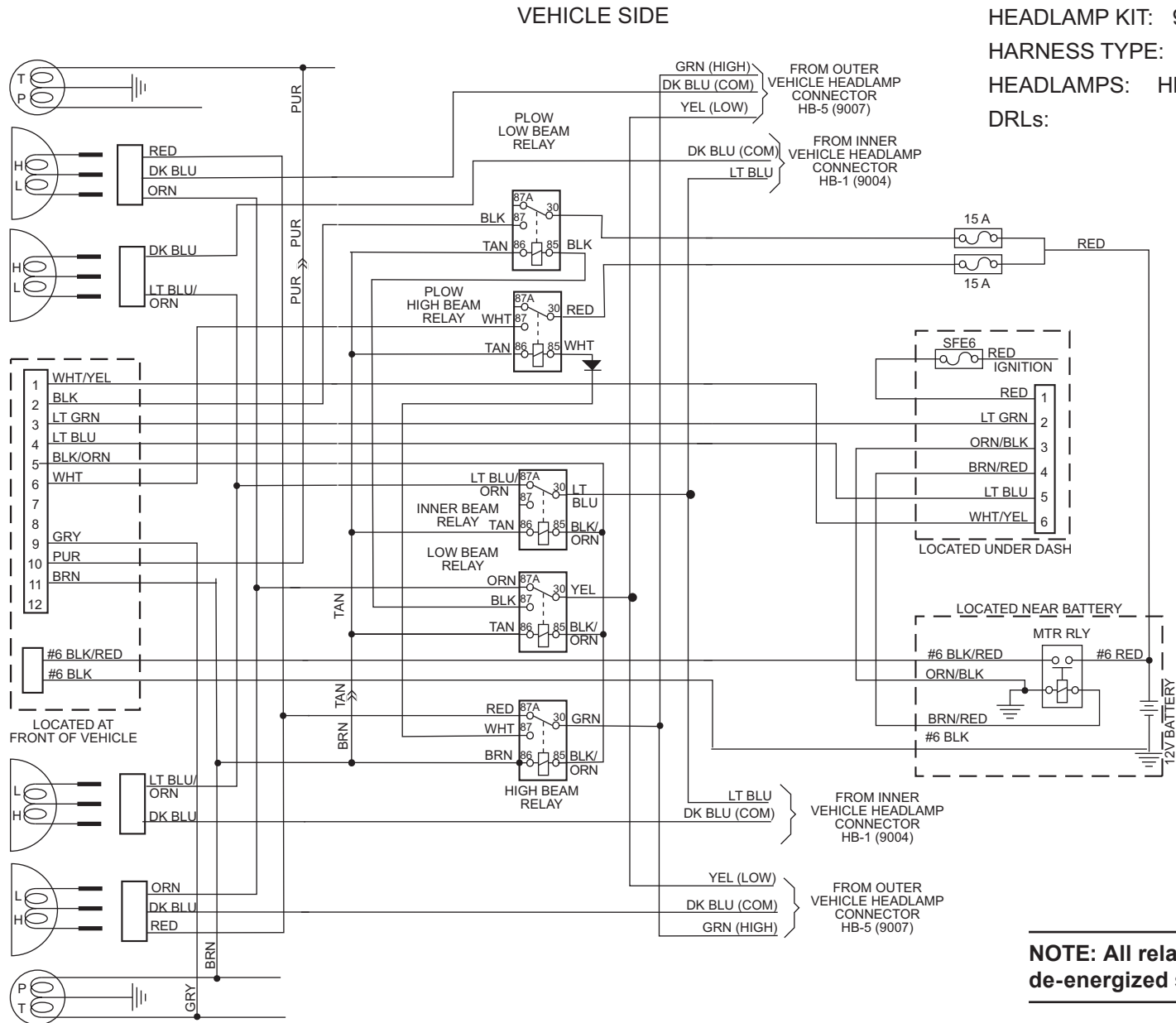
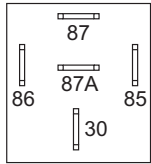

13607-98
63103-91

NOTE: All relays are shown in the de-energized state.

9-PIN HARNESS

Headlamp Relay Terminal Locations

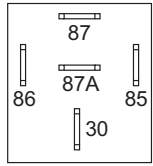

VEHICLE SIDE

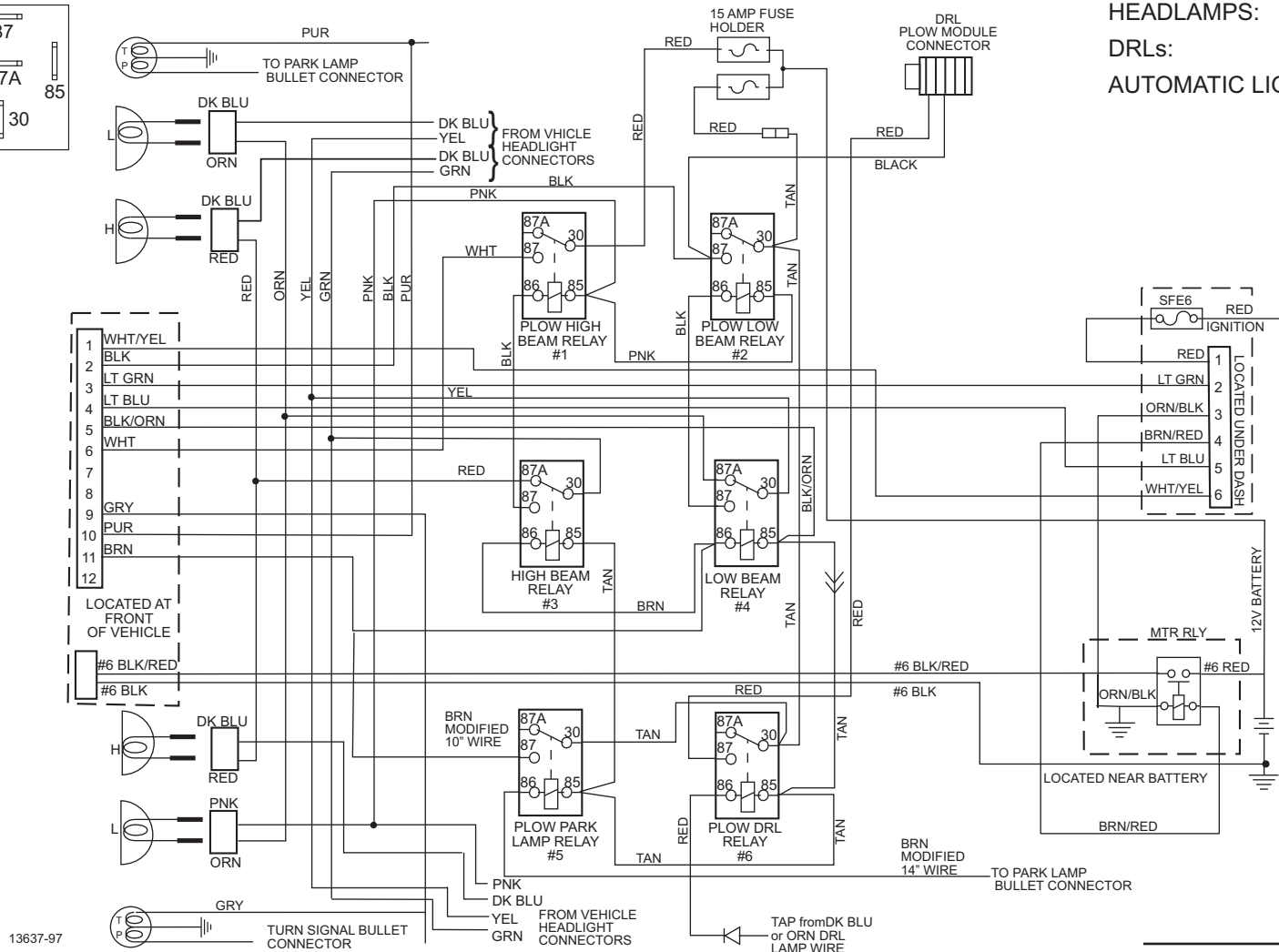

HEADLAMP KIT: 9 PIN
 HARNESS TYPE: F
 HEADLAMPS: HB3/HB4
 DRLs: YES
 AUTOMATIC LIGHT SYSTEM

NOTE: All relays are shown in the de-energized state.

9-PIN HARNESS

VEHICLE SIDE

HEADLAMP KIT: 9 PIN
 HARNESS TYPE: G
 HEADLAMPS: HB5
 DRLs: NO

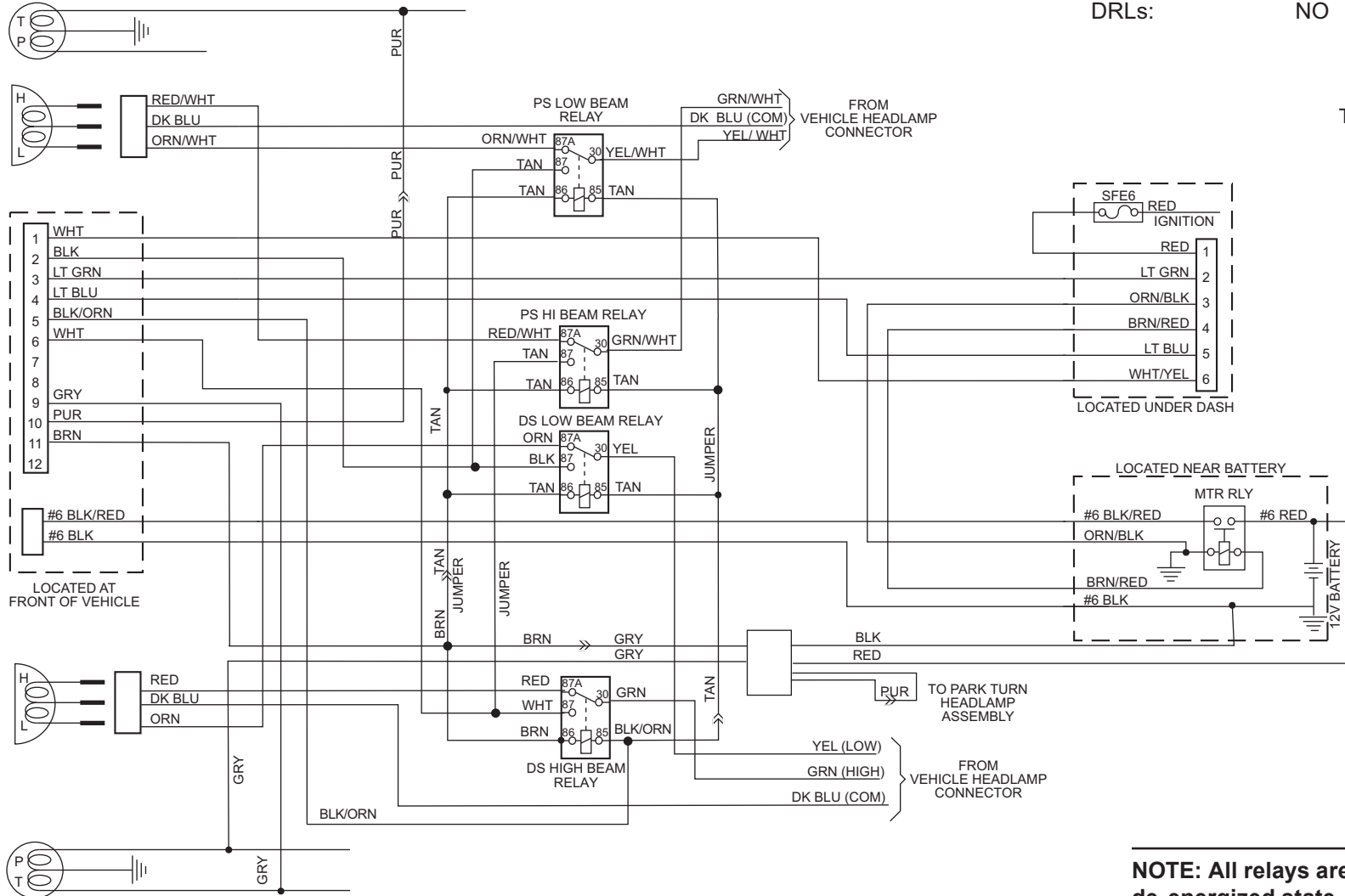

Headlamp Relay Terminal Locations

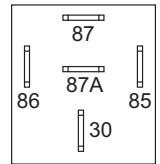

67

13607-98
63103-91

NOTE: All relays are shown in the de-energized state.

9-PIN HARNESS

VEHICLE SIDE

HEADLAMP KIT: 9 PIN
 HARNESS TYPE: G
 HEADLAMPS: HB5
 DRLs: NO

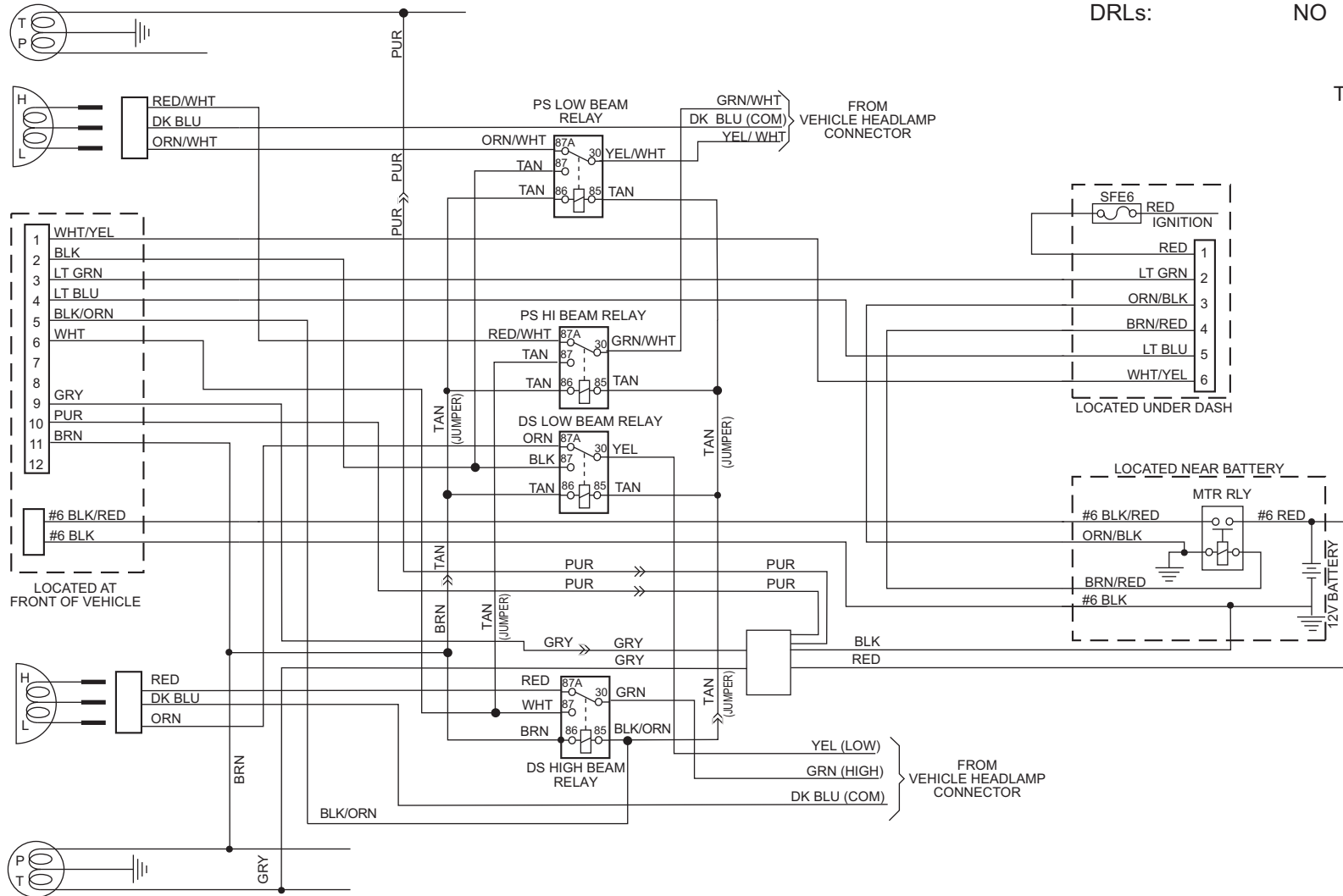

Headlamp Relay Terminal Locations

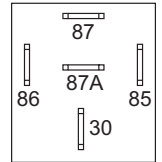

9-PIN HARNESS

VEHICLE SIDE

HEADLAMP KIT: 9 PIN
 HARNESS TYPE: G
 HEADLAMPS: HB5
 DRLs: YES

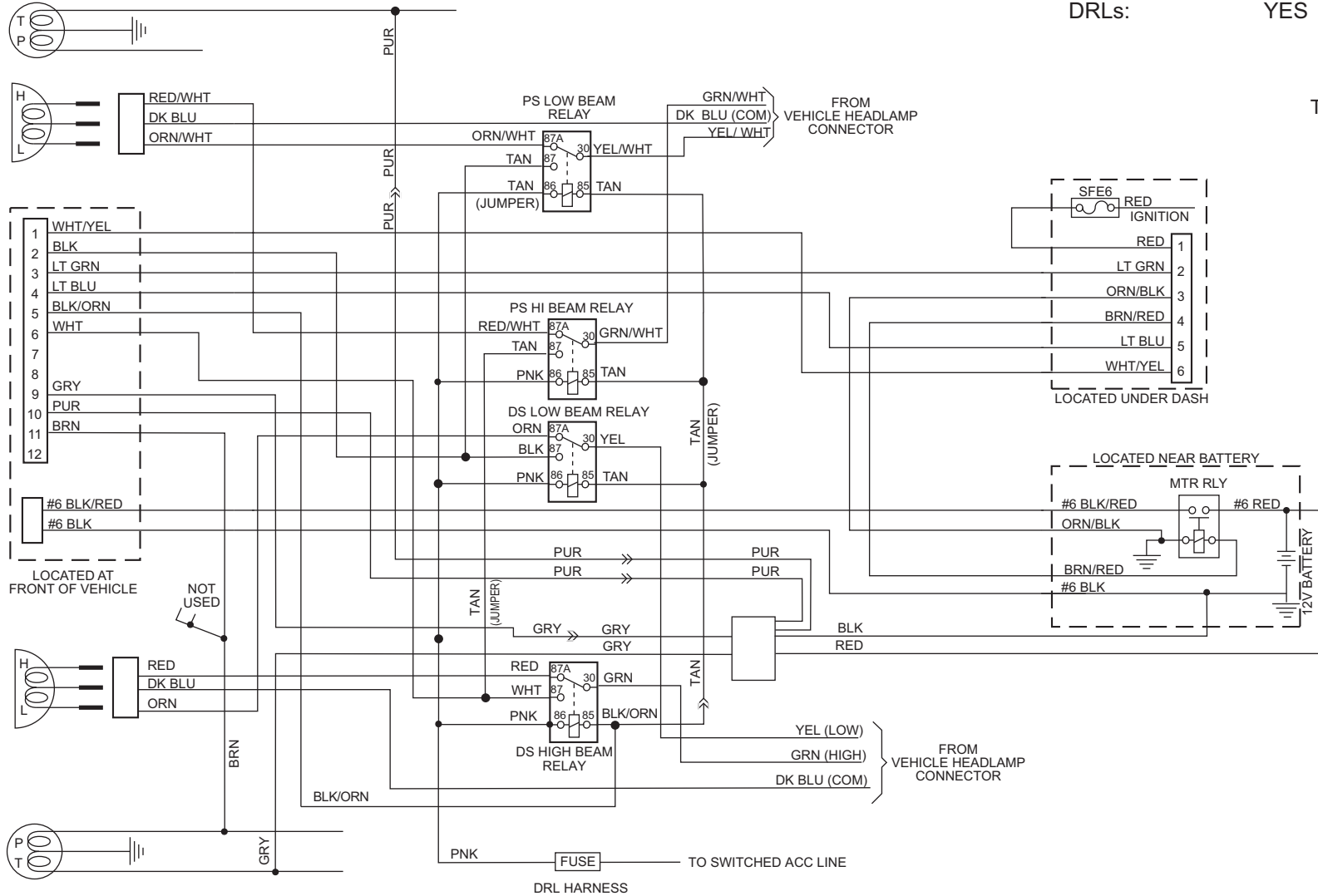

Headlamp Relay Terminal Locations

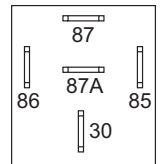

9-PIN HARNESS

VEHICLE SIDE

HEADLAMP KIT: 9 PIN
 HARNESS TYPE: G
 HEADLAMPS: HB5
 DRLs: YES

Headlamp Relay
Terminal Locations

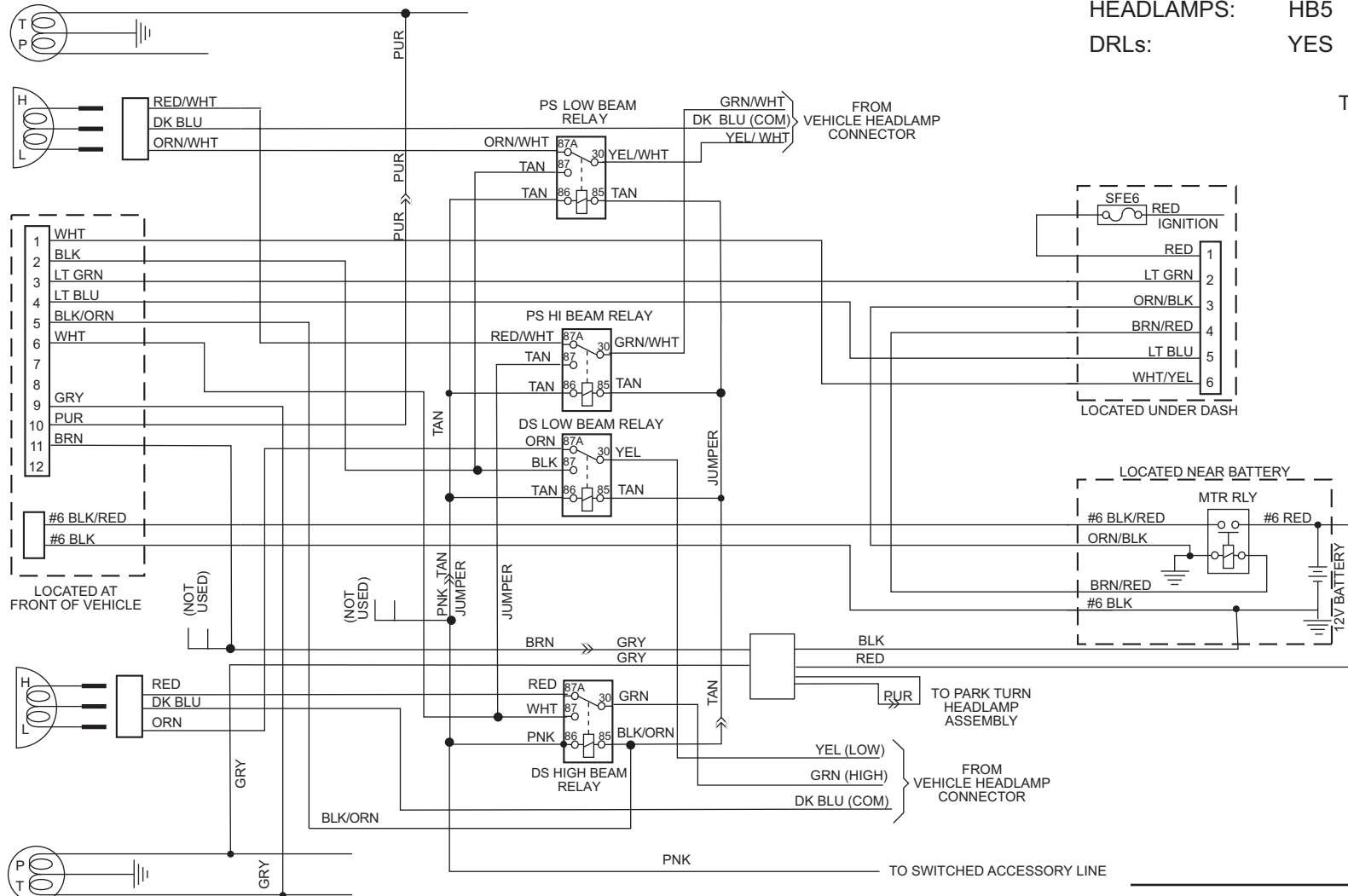
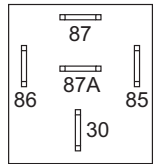

13607-98
63103-91

NOTE: All relays are shown in the de-energized state.

ELECTRICAL SCHEMATIC – 12-PIN VEHICLE HARNESS – REVISION 8 AND LATER

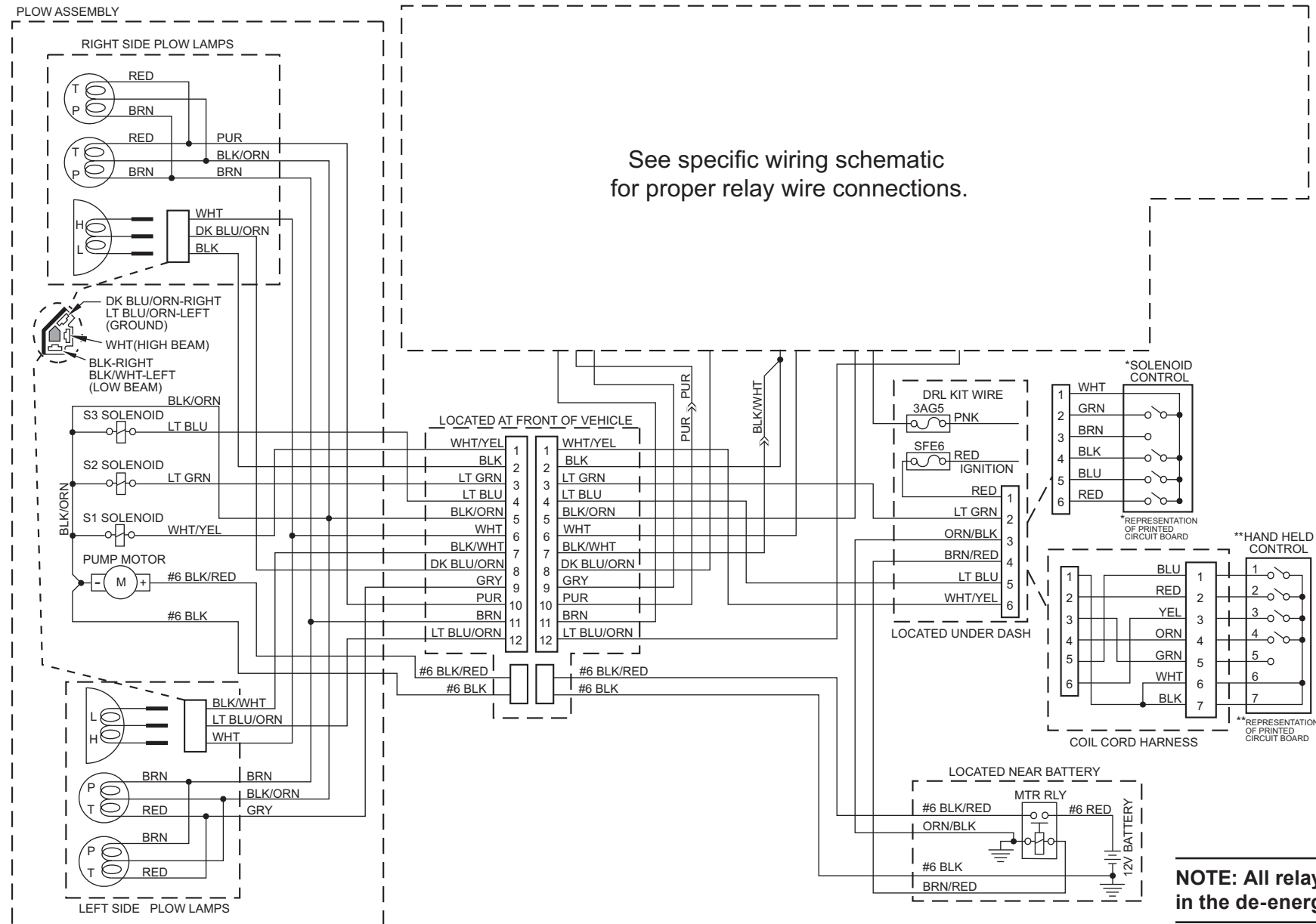

ELECTRICAL SCHEMATIC – 12-PIN VEHICLE HARNESS – REVISION 1-7

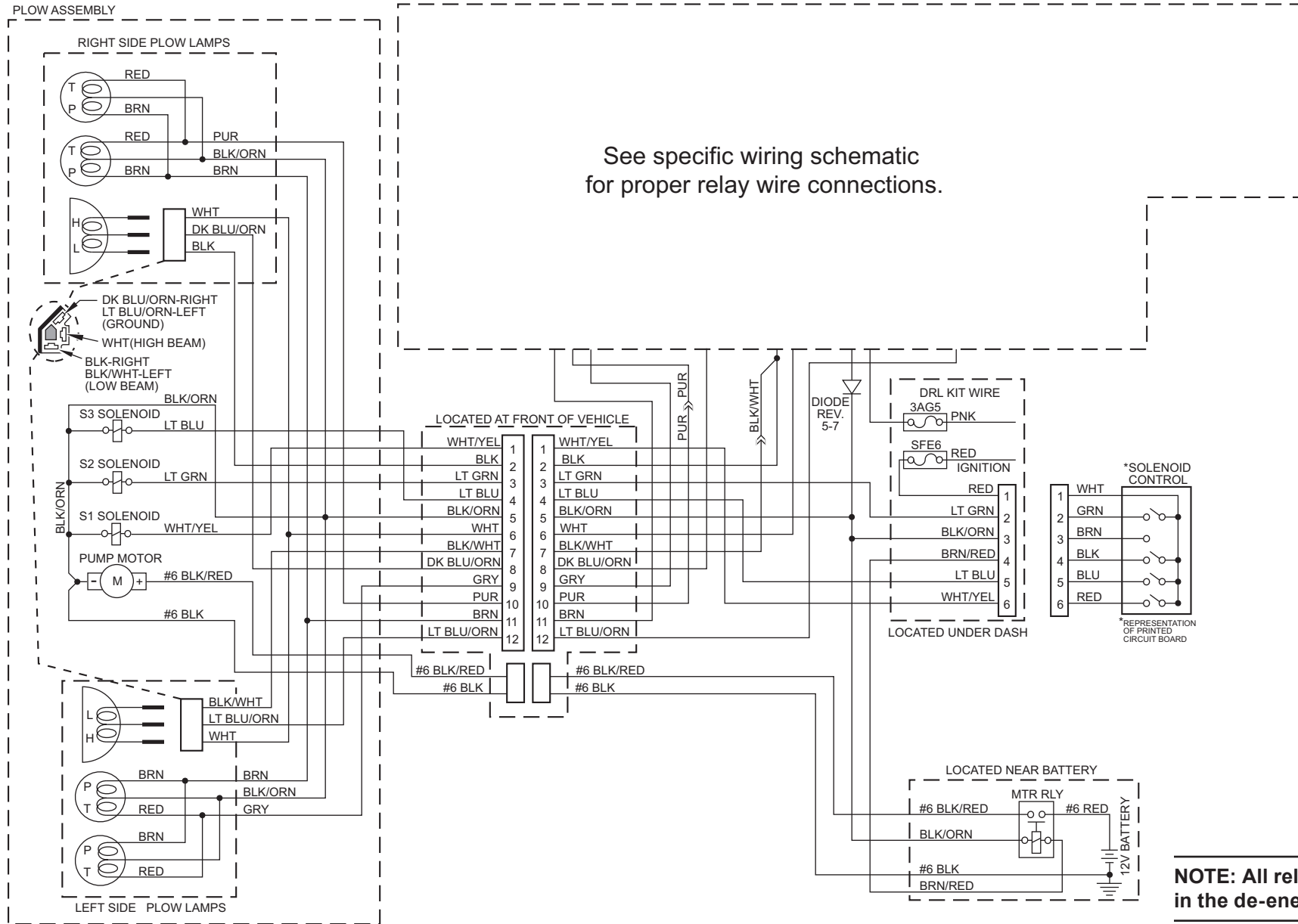

12-PIN HARNESS

PLOW SIDE

HEADLAMP KIT: 12 PIN

Headlamp Relay Terminal Locations

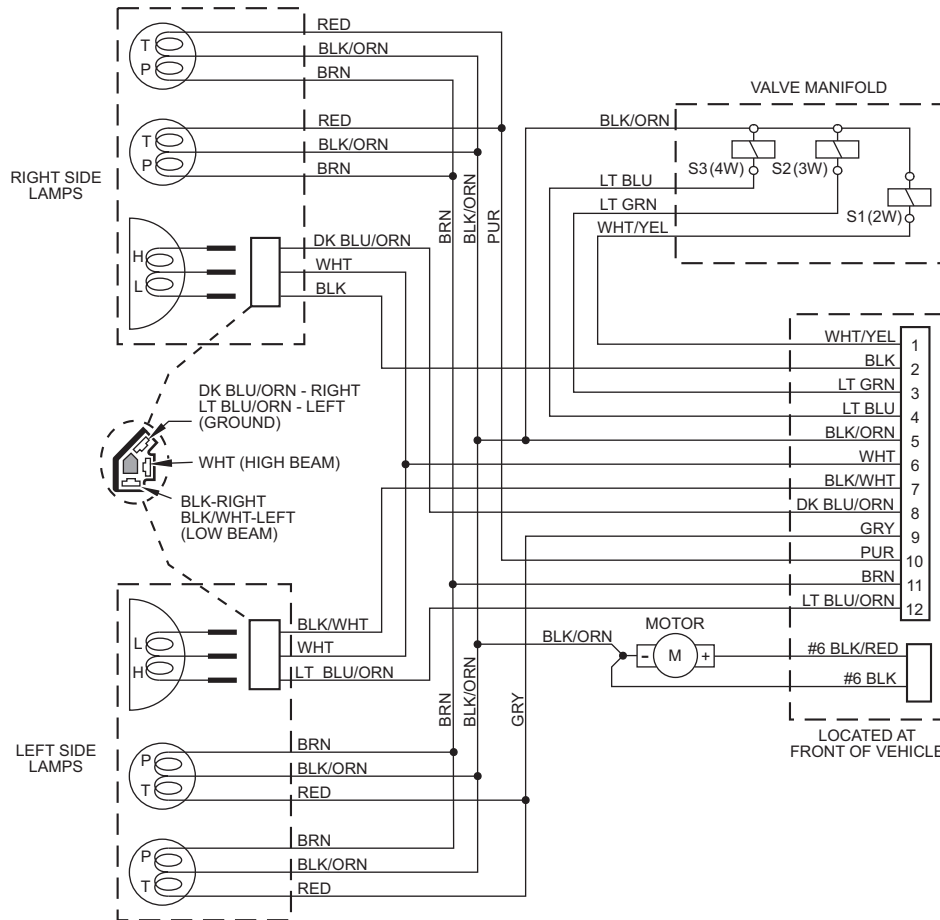
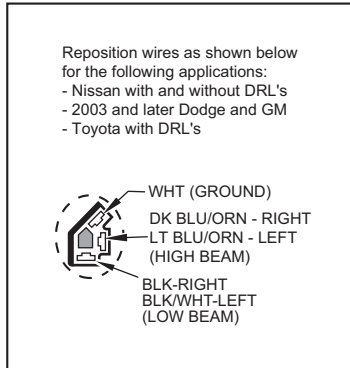
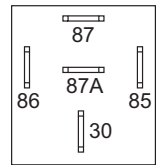

LOCATED AT FRONT OF VEHICLE

12-PIN HARNESS

Headlamp Relay
Terminal Locations

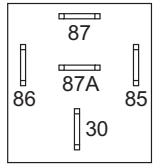

VEHICLE SIDE

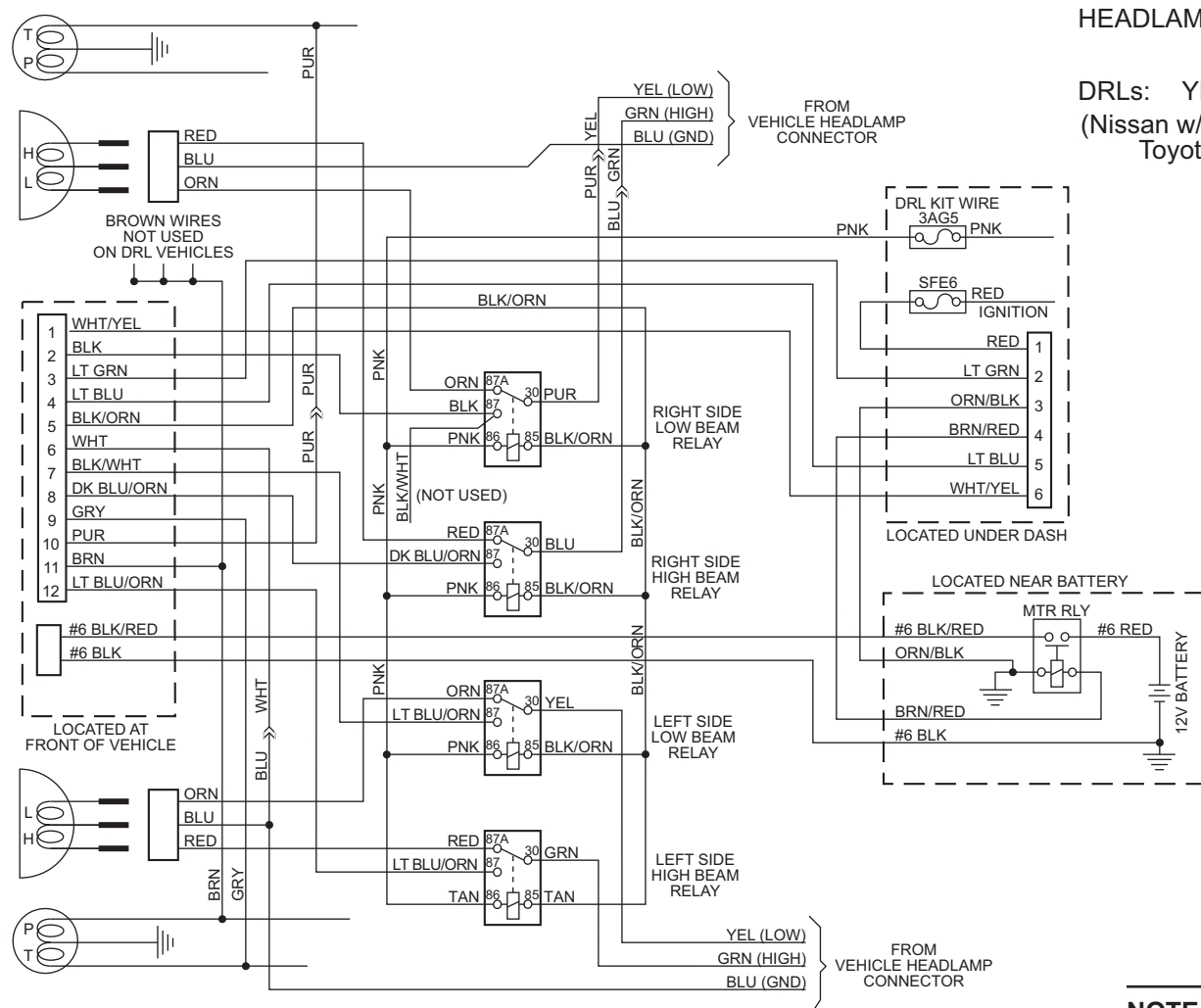

HEADLAMP KIT: 12 PIN
 HARNESS TYPE: A
 (combines 2 harnesses)
 HEADLAMPS: 2B/2D
 HB1
 DRLs: YES/NO
 (Nissan w/ and w/o DRLs;
 Toyota w/DRLs)

13600-98

NOTE: All relays are shown in the de-energized state.

12-PIN HARNESS

VEHICLE SIDE

HEADLAMP KIT: 12 PIN
 HARNESS TYPE: B
 HEADLAMPS: 2B/2D
 DRLs: NO

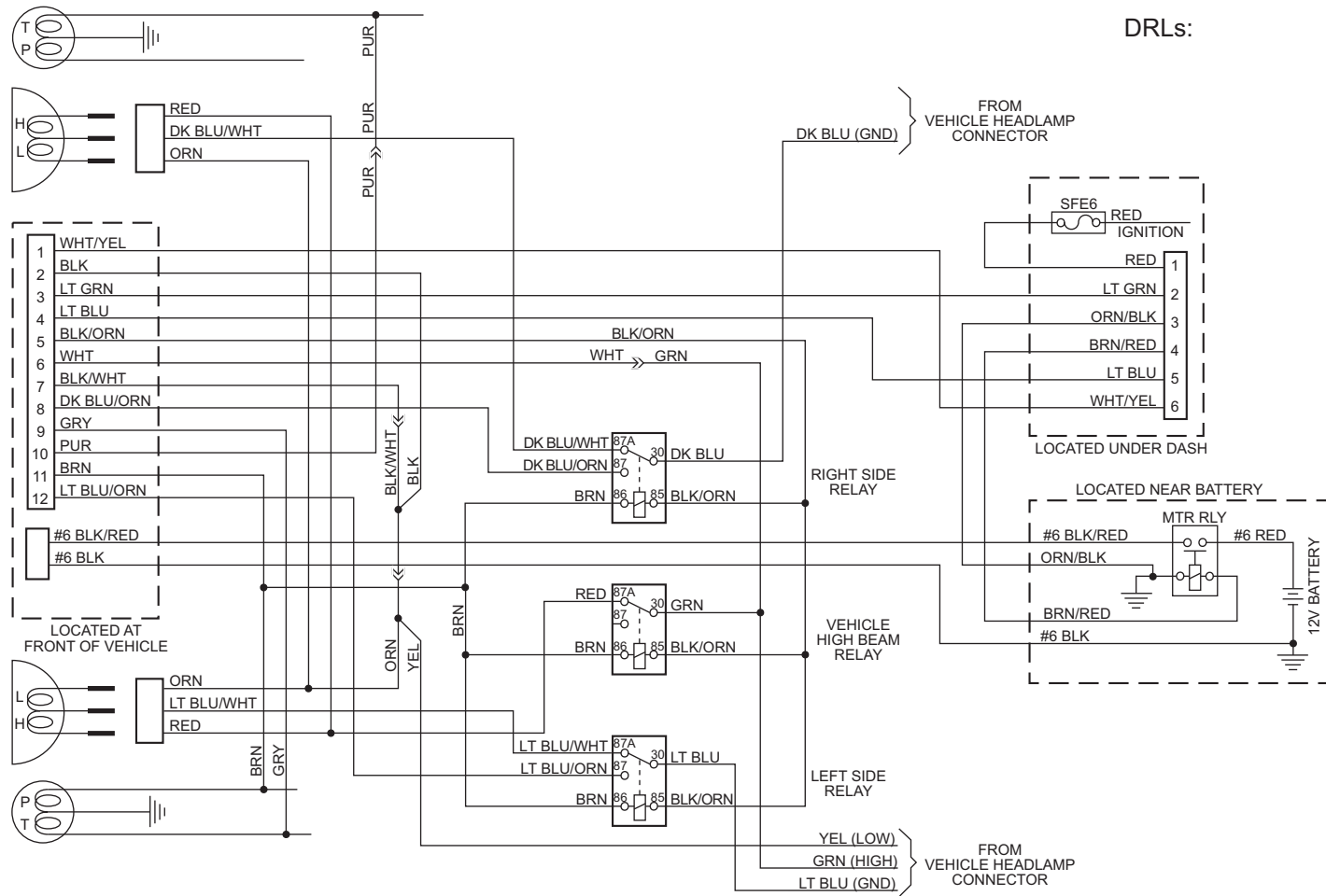

Headlamp Relay Terminal Locations

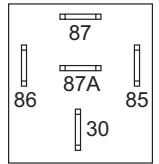

75

13625-92

NOTE: All relays are shown in the de-energized state.

12-PIN HARNESS

Headlamp Relay
Terminal Locations

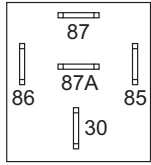

VEHICLE SIDE

HEADLAMP KIT: 12 PIN

HARNESS TYPE: B
(combines 2 harnesses)

HEADLAMPS: HB1

DRLs: NO

13625-97

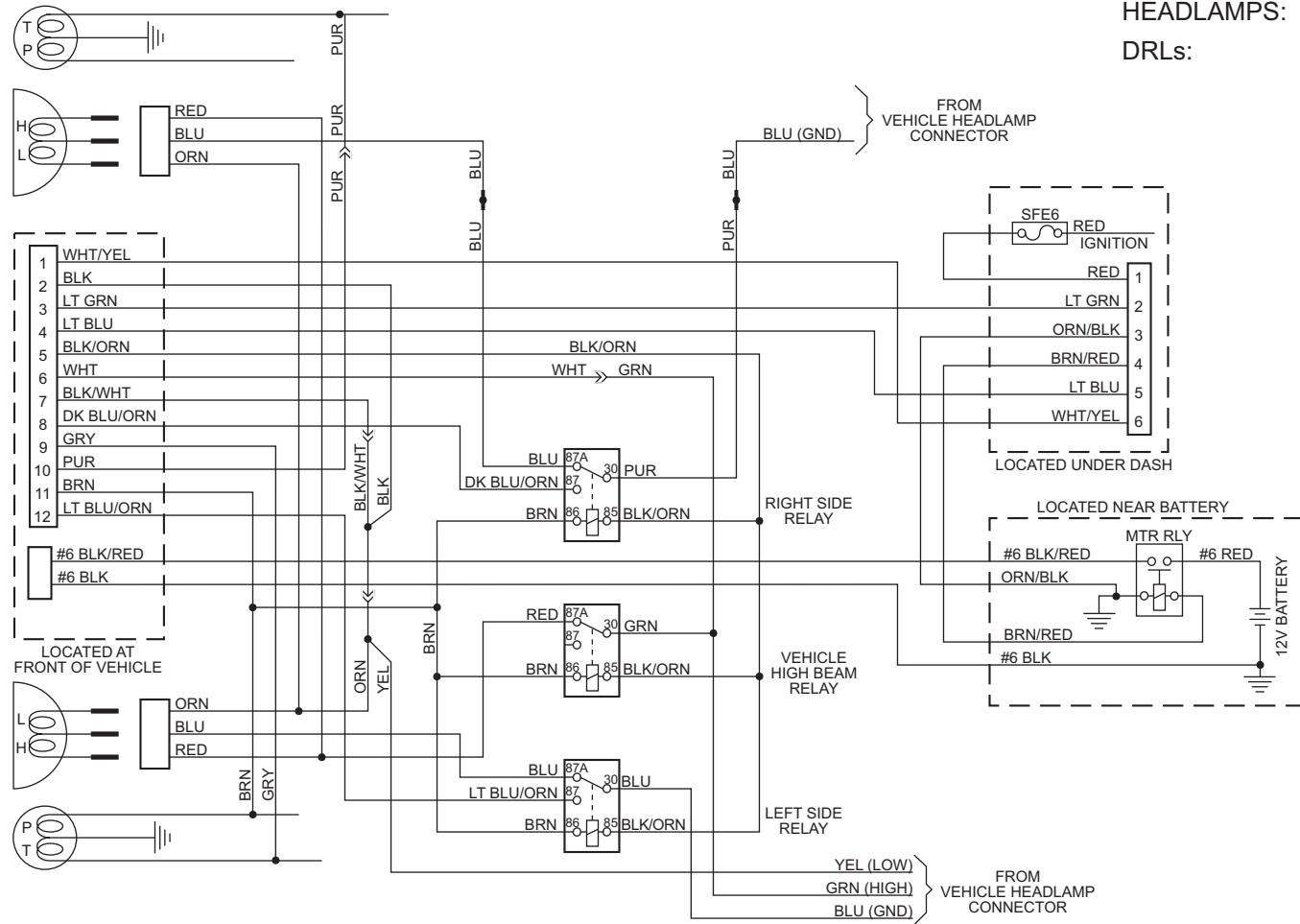

76

NOTE: All relays are shown in the de-energized state.

12-PIN HARNESS

Headlamp Relay
Terminal Locations

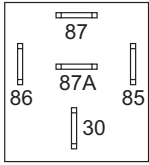

VEHICLE SIDE

HEADLAMP KIT: 12 PIN

HARNESS TYPE: B

HEADLAMPS: 2B/2D

2E

(Early GM applications used
two harnesses spliced together)

DRLs: YES

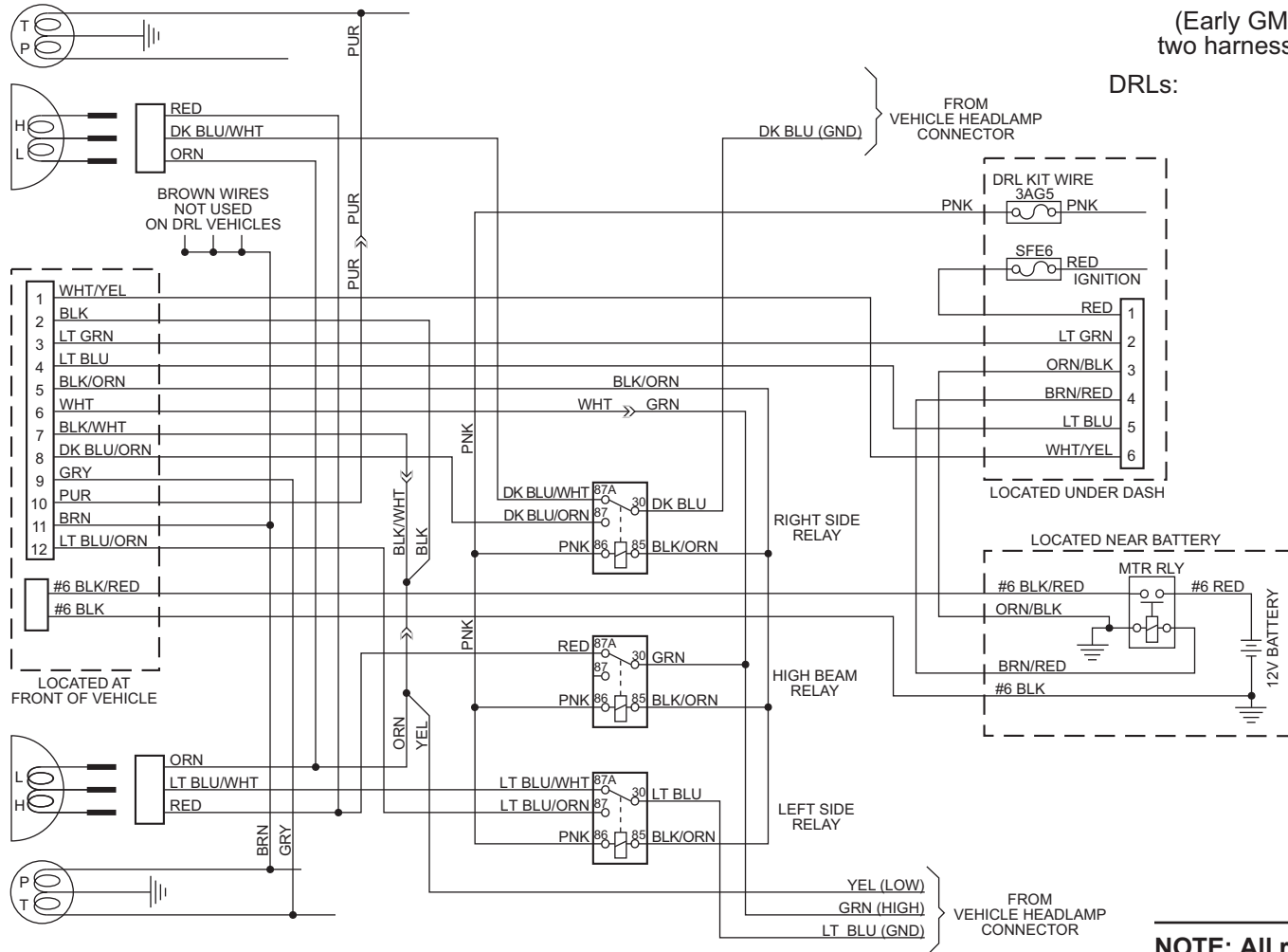

77

NOTE: All relays are shown in the de-energized state.

12-PIN HARNESS

Headlamp Relay Terminal Locations

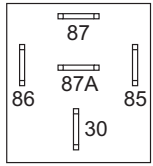

VEHICLE SIDE

HEADLAMP KIT: 12 PIN
HARNESS TYPE: B
HEADLAMPS: HB3 /HB4
DRLs: YES

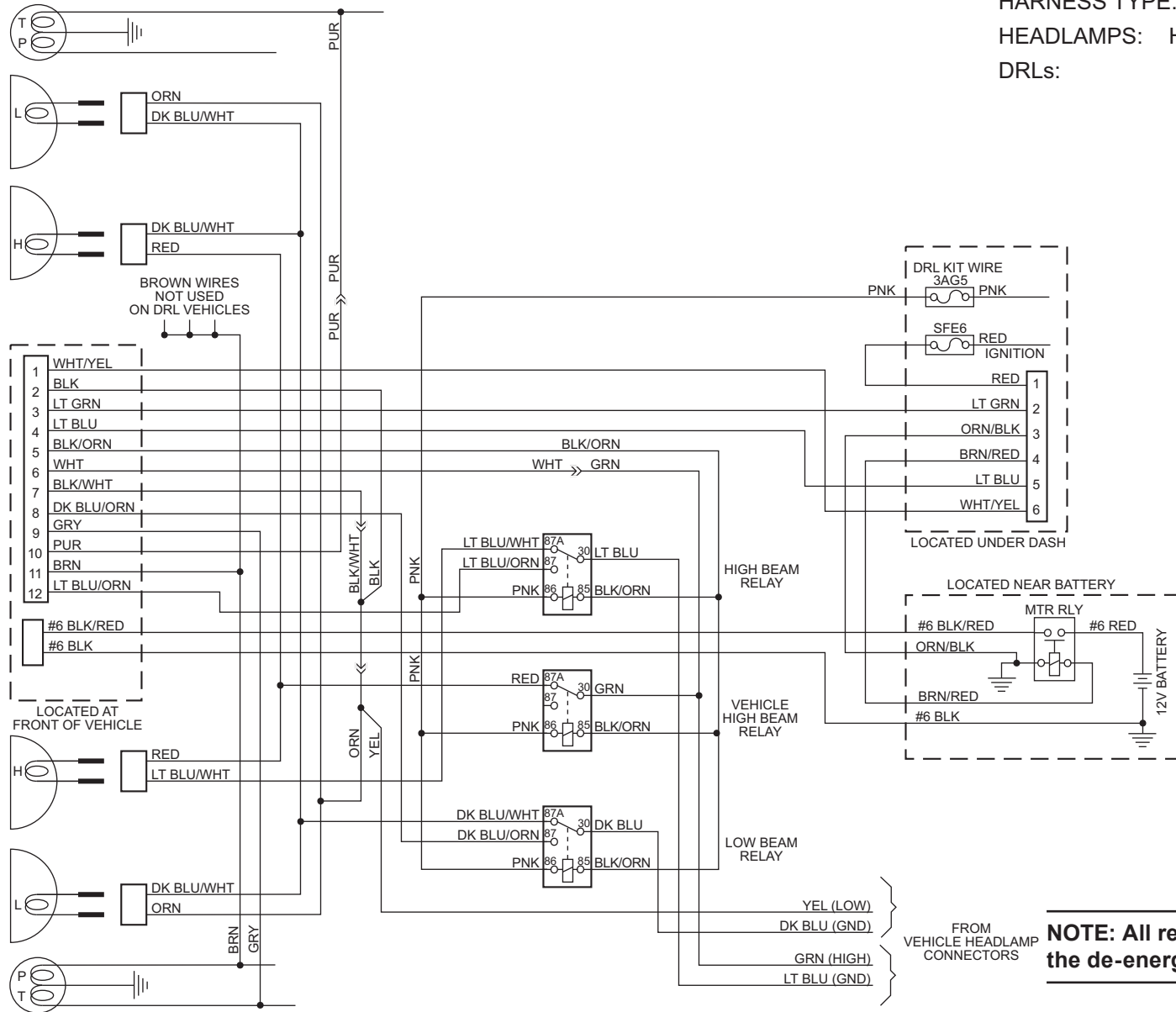

12-PIN HARNESS

Headlamp Relay Terminal Locations

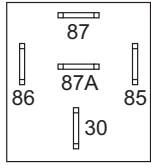

VEHICLE SIDE

HEADLAMP KIT: 12 PIN
 HARNESS TYPE: B
 HEADLAMPS: LF/UF
 DRLs: YES

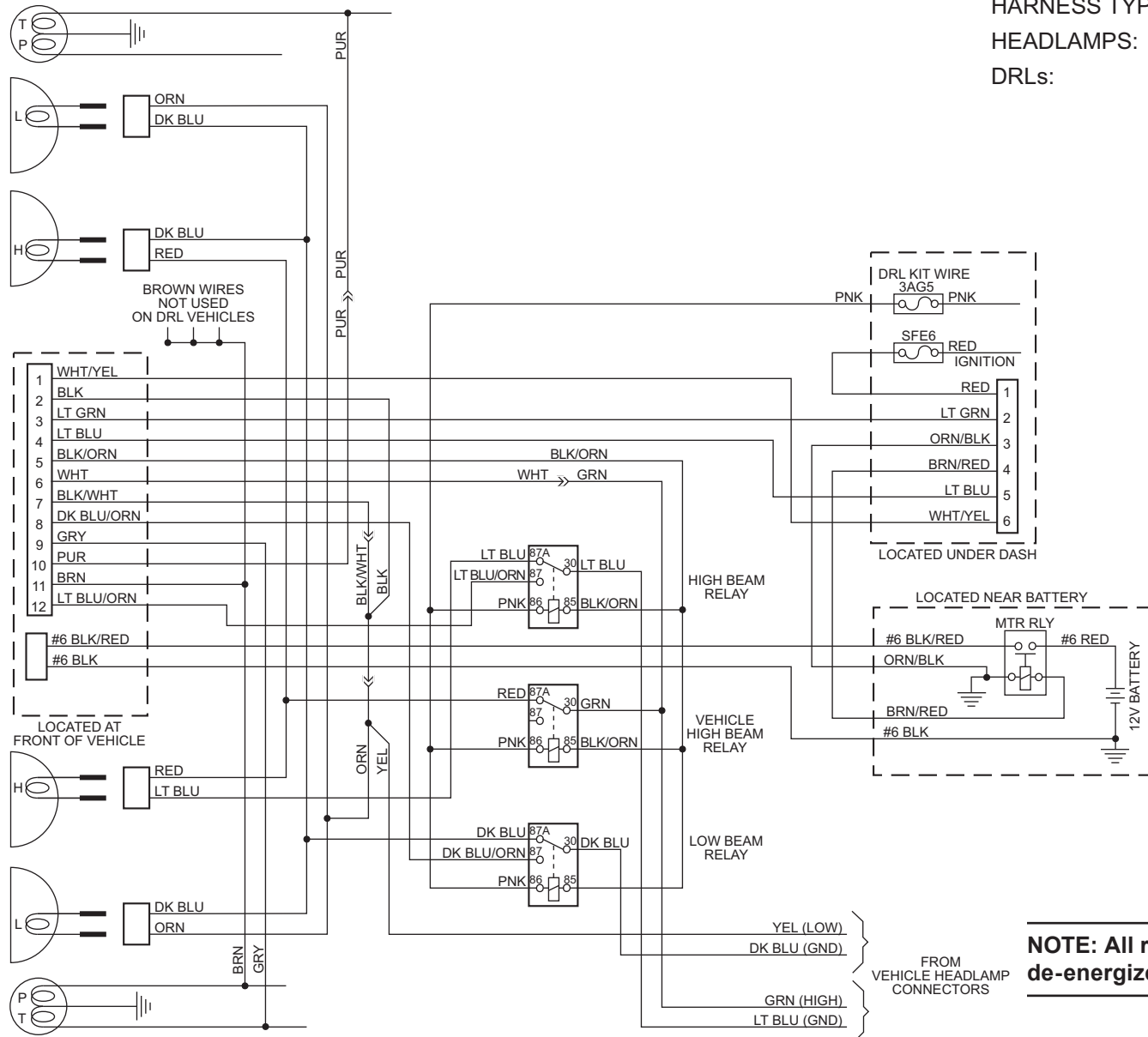

13609-98

12-PIN HARNESS

Headlamp Relay Terminal Locations

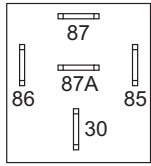

VEHICLE SIDE

HEADLAMP KIT: 12 PIN
 HARNESS TYPE: D
 HEADLAMPS: HB3/HB4
 DRLs: YES
 (Automatic, DRL kit not required)

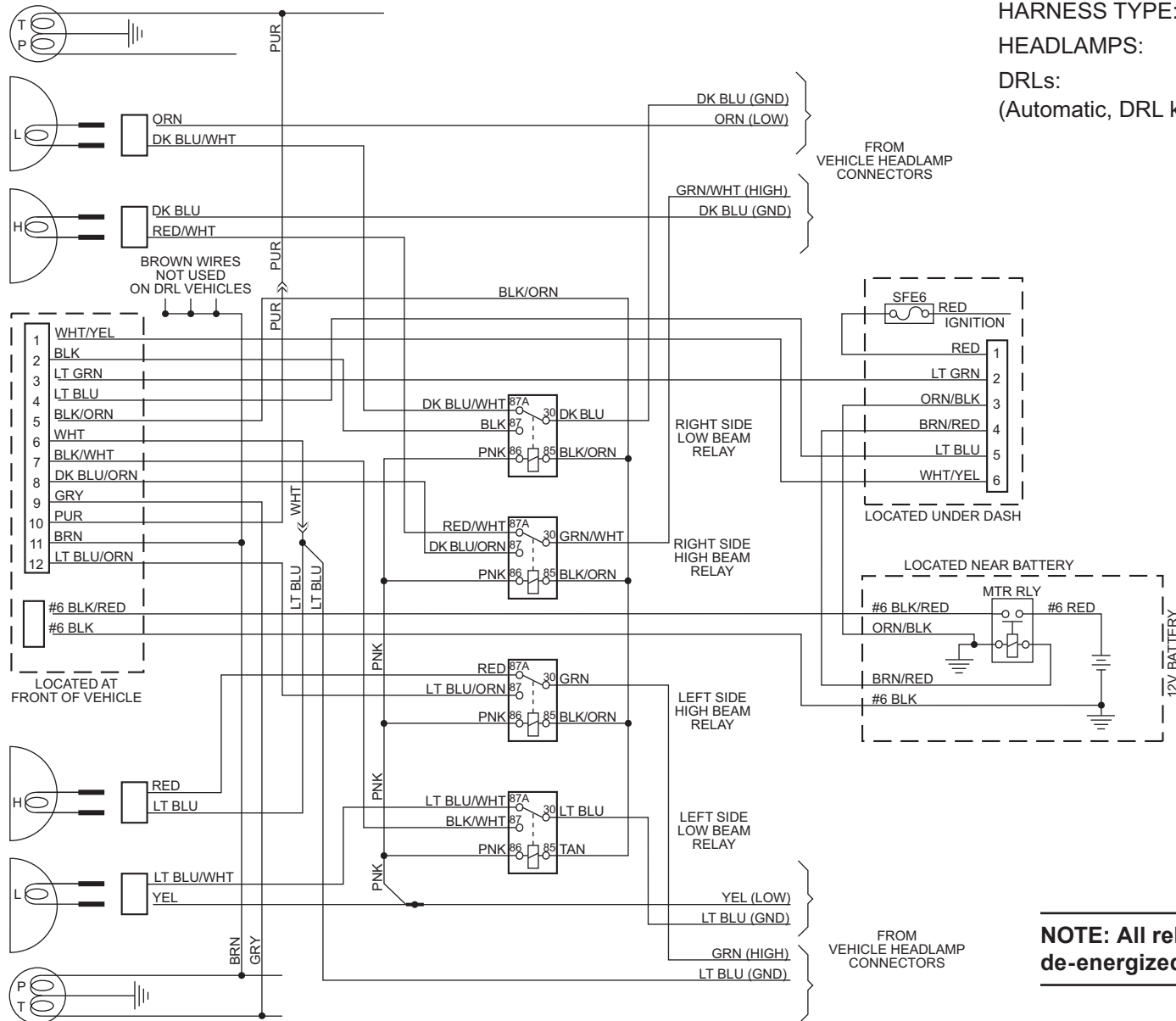

NOTE: All relays are shown in the de-energized state.

62914-97

12-PIN HARNESS

Headlamp Relay
Terminal Locations

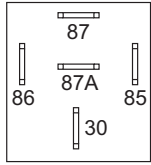

VEHICLE SIDE

HEADLAMP KIT: 12 PIN
HARNESS TYPE: F
HEADLAMPS: HB1
DRLs: YES

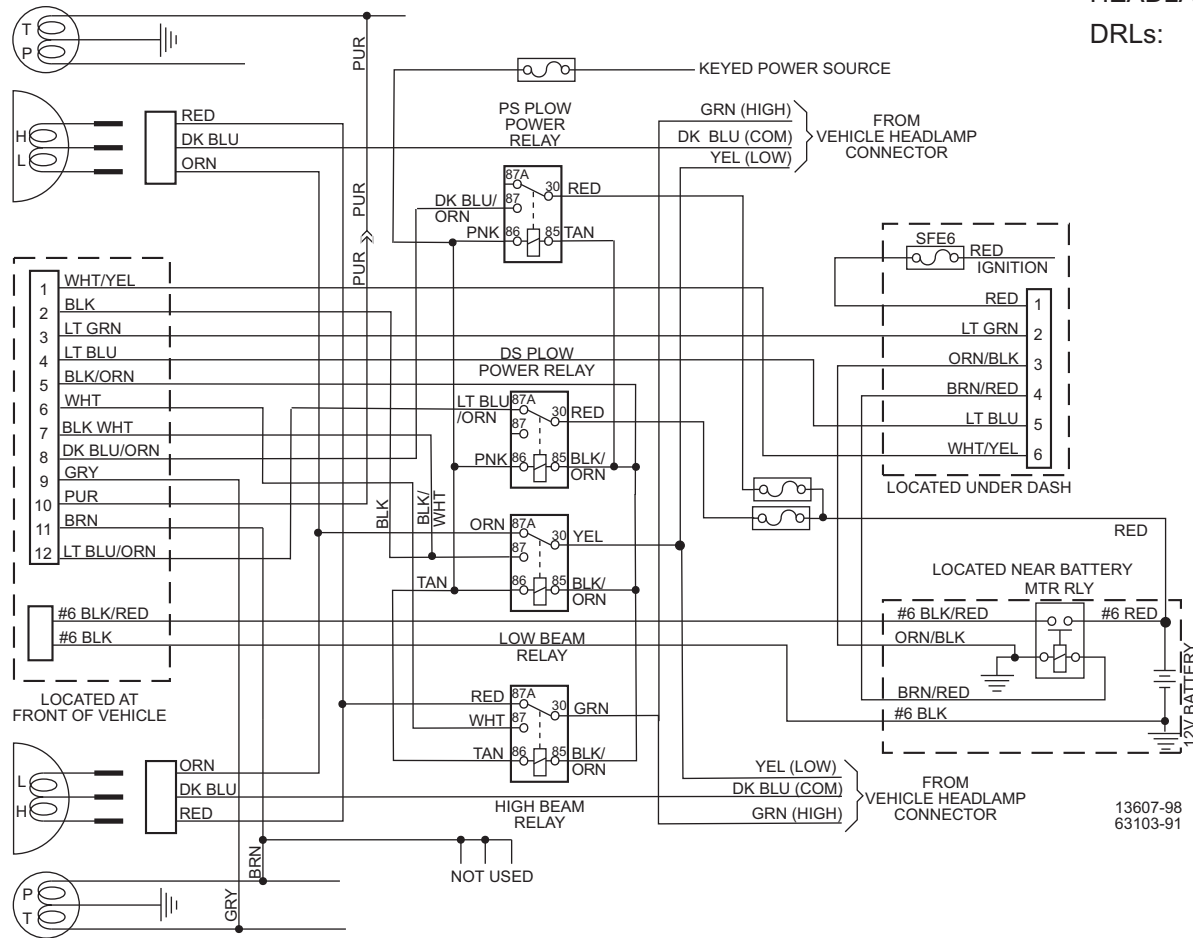

13607-98
63103-91

NOTE: All relays are shown in the de-energized state.

12-PIN HARNESS

Headlamp Relay Terminal Locations

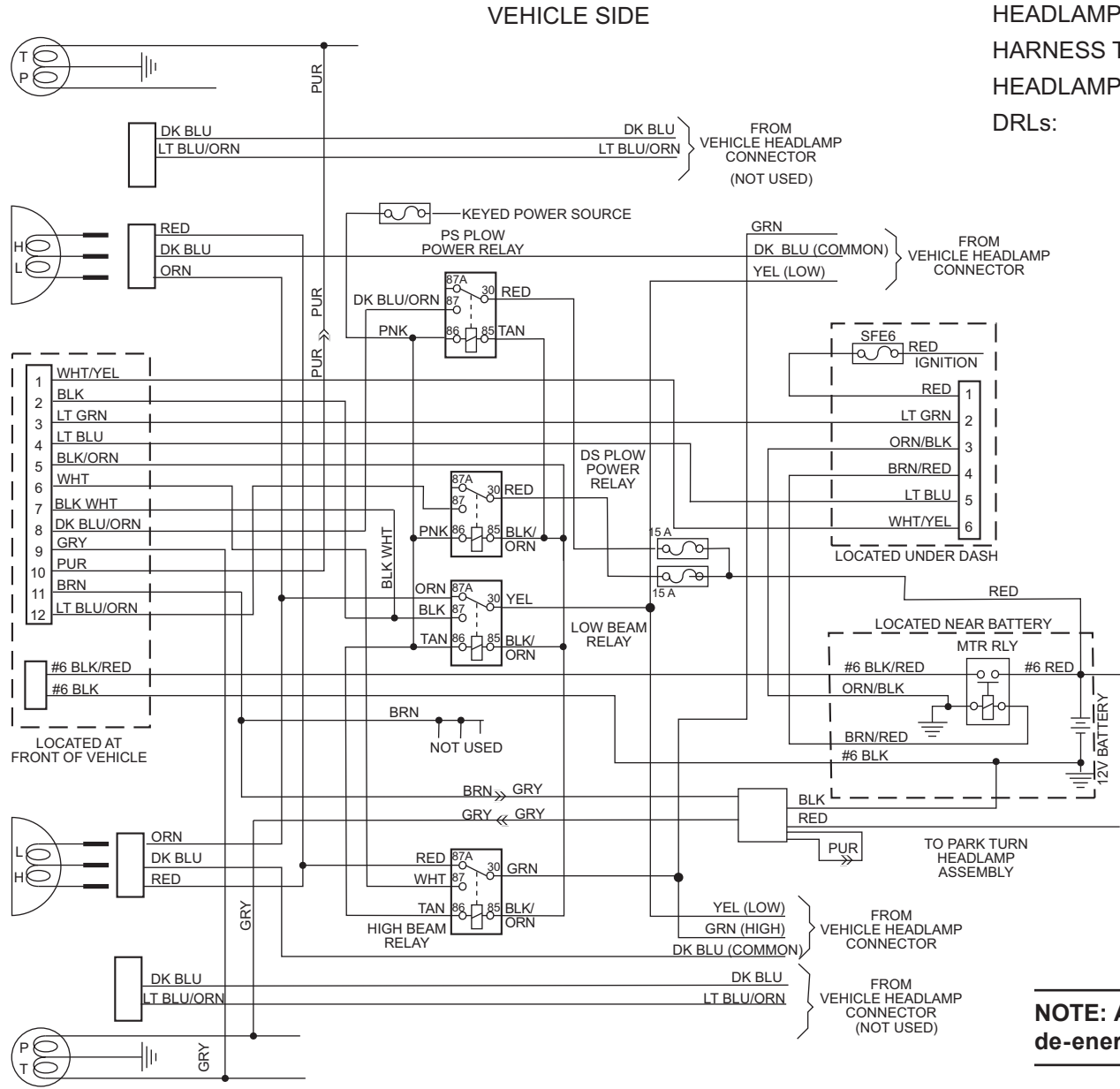
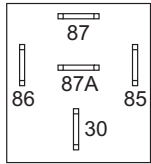

13607-98
63103-91

NOTE: All relays are shown in the de-energized state.

12-PIN HARNESS

Headlamp Relay Terminal Locations

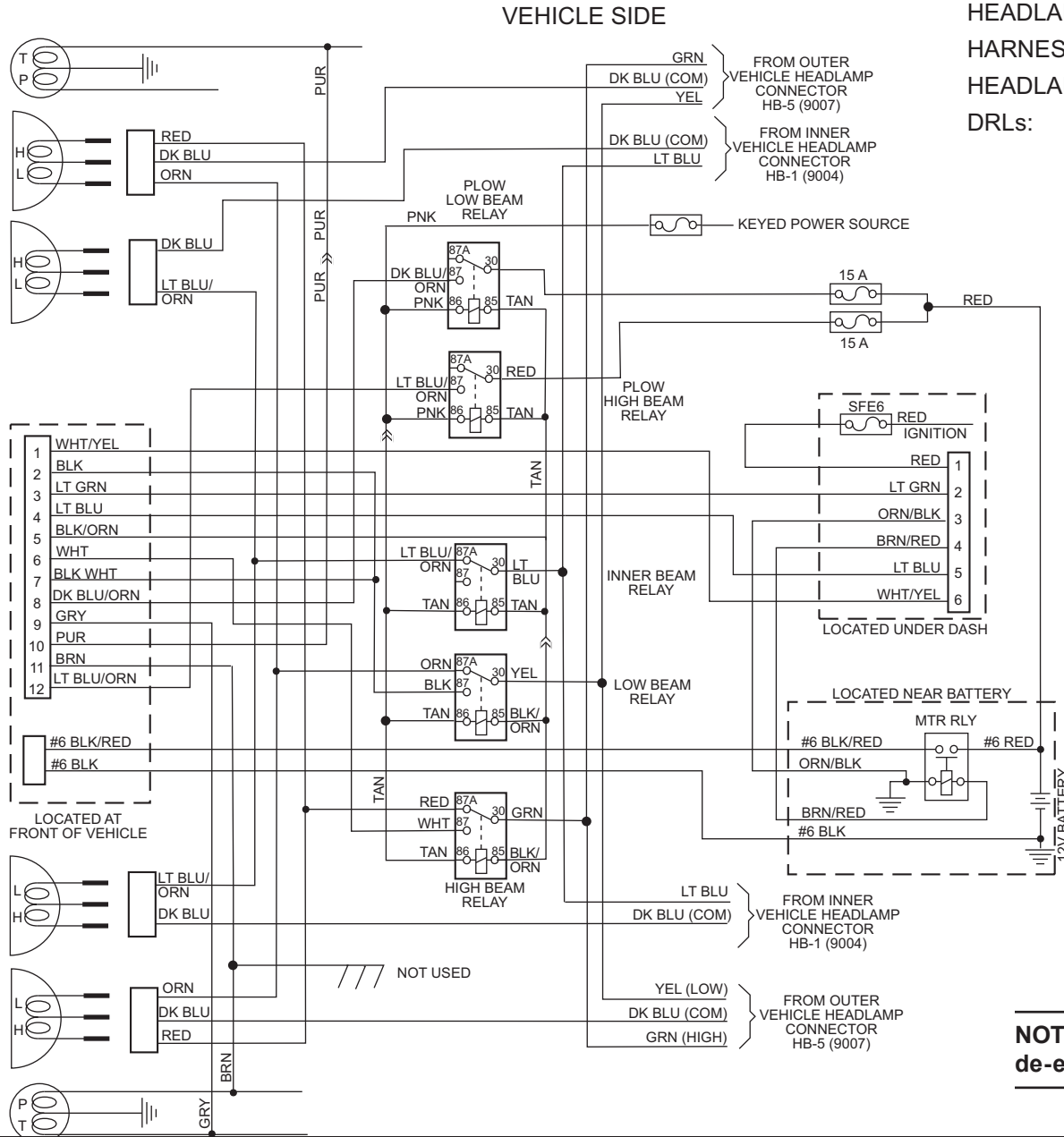
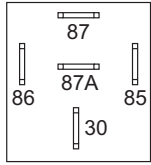

HEADLAMP KIT: 12 PIN
 HARNESS TYPE: F
 HEADLAMPS: HB1/HB5
 DRLs: YES

NOTE: All relays are shown in the de-energized state.

13607-98
 63103-91

12-PIN HARNESS

VEHICLE SIDE

HEADLAMP KIT: 12 PIN
 HARNESS TYPE: G
 HEADLAMPS: HB5
 DRLs: NO

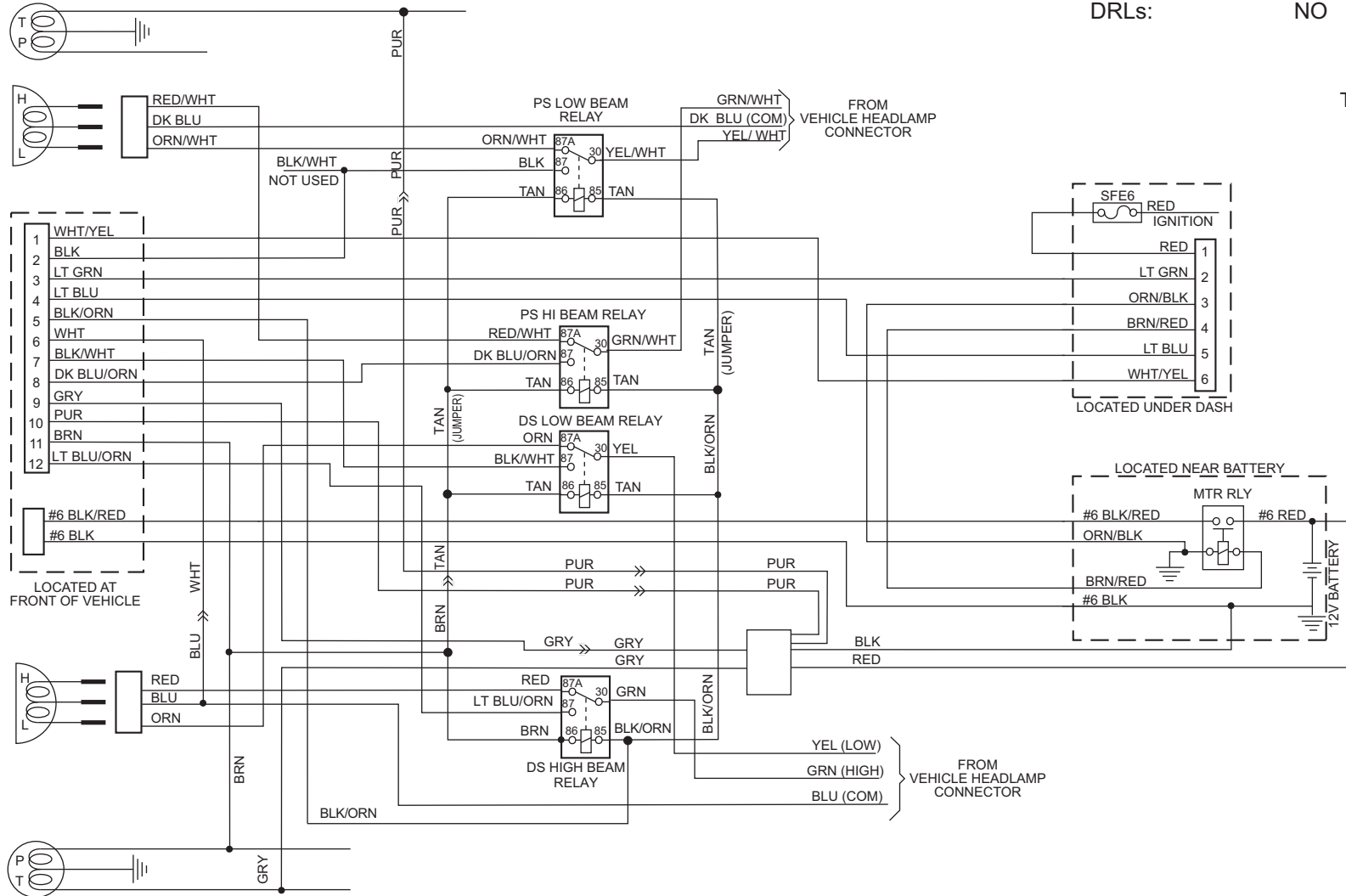

Headlamp Relay Terminal Locations

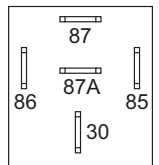

12-PIN HARNESS

VEHICLE SIDE

HEADLAMP KIT: 12 PIN
 HARNESS TYPE: G
 HEADLAMPS: HB5
 DRLs: YES

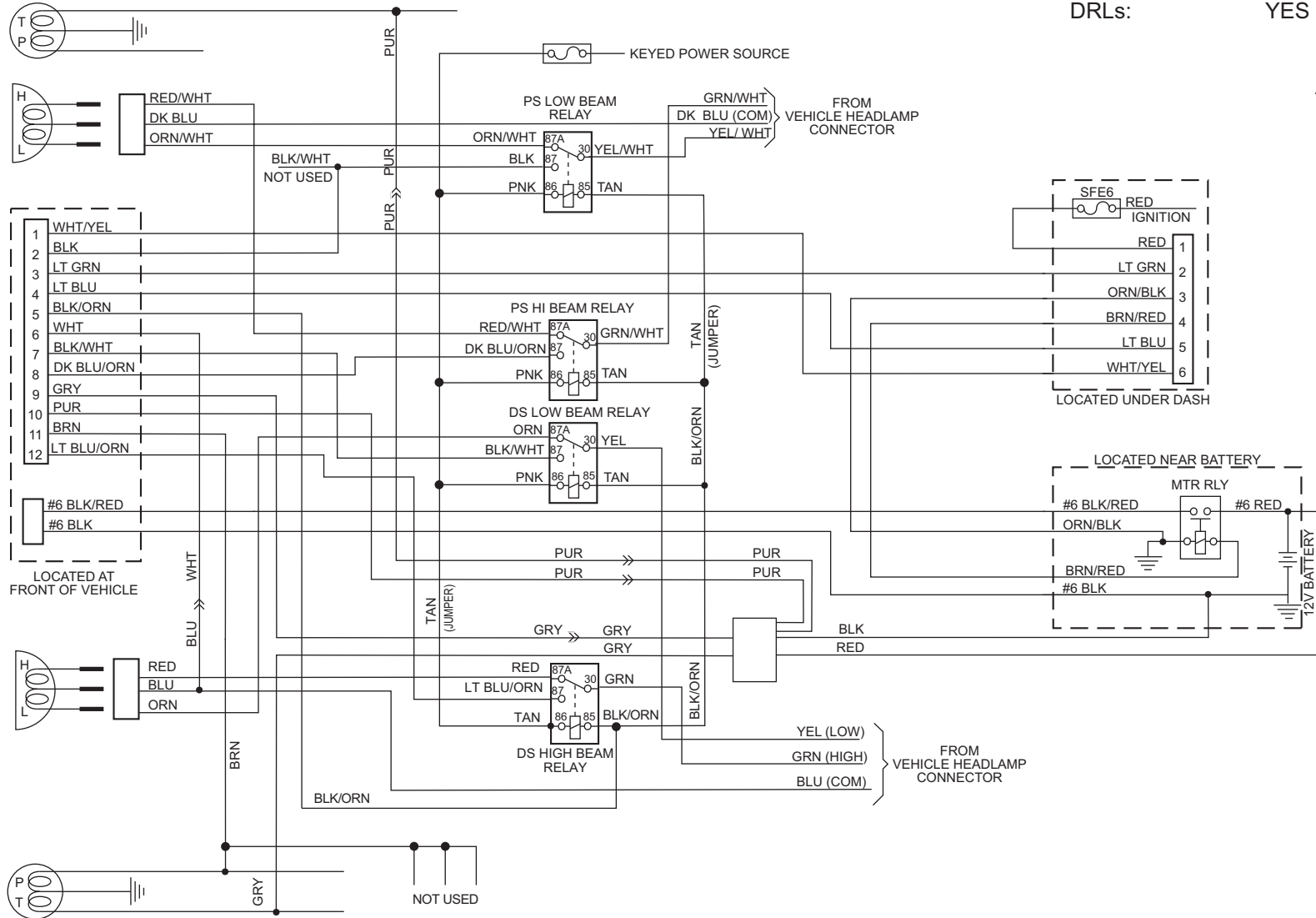

Headlamp Relay Terminal Locations

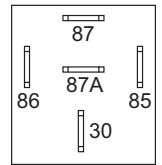

12-PIN HARNESS

VEHICLE SIDE

HEADLAMP KIT: 12 PIN

HARNESS TYPE: H

HEADLAMPS: HB3/HB4

DRLs: YES

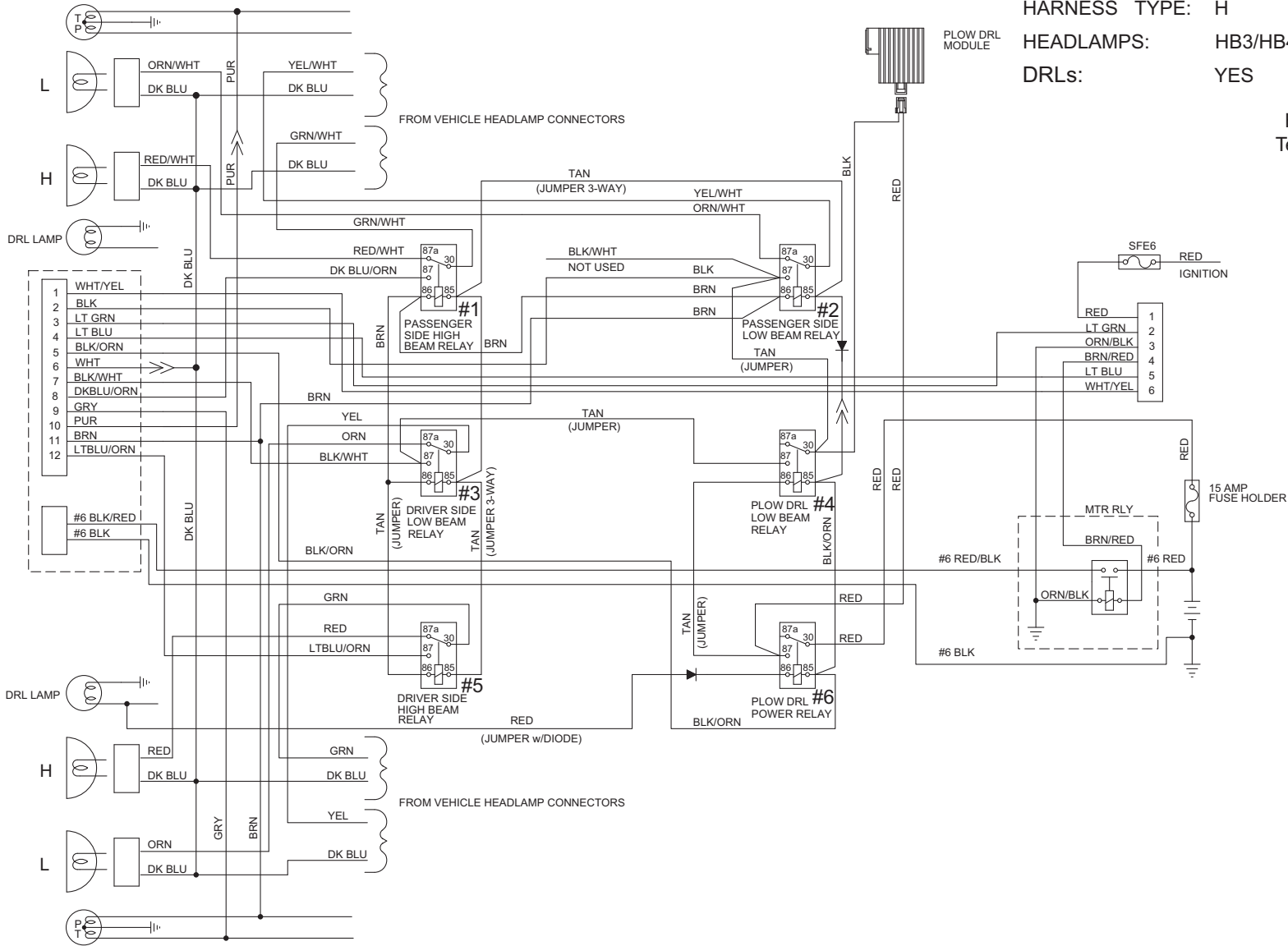

Headlamp Relay Terminal Locations

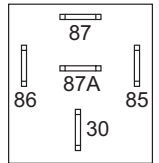

MVP® ELECTRICAL SCHEMATIC

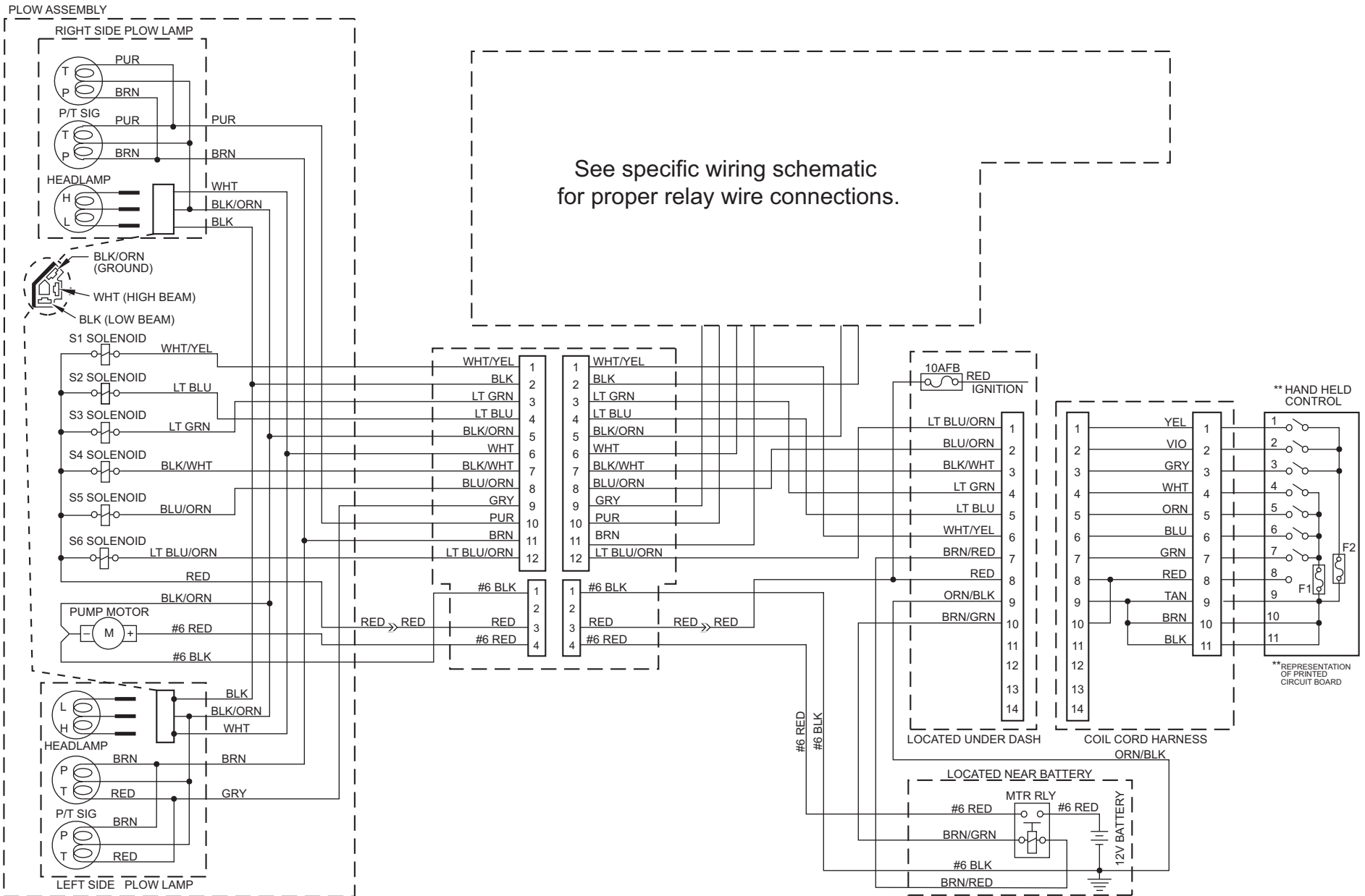

MVP® ELECTRICAL SCHEMATIC – For 2003 GM and Dodge

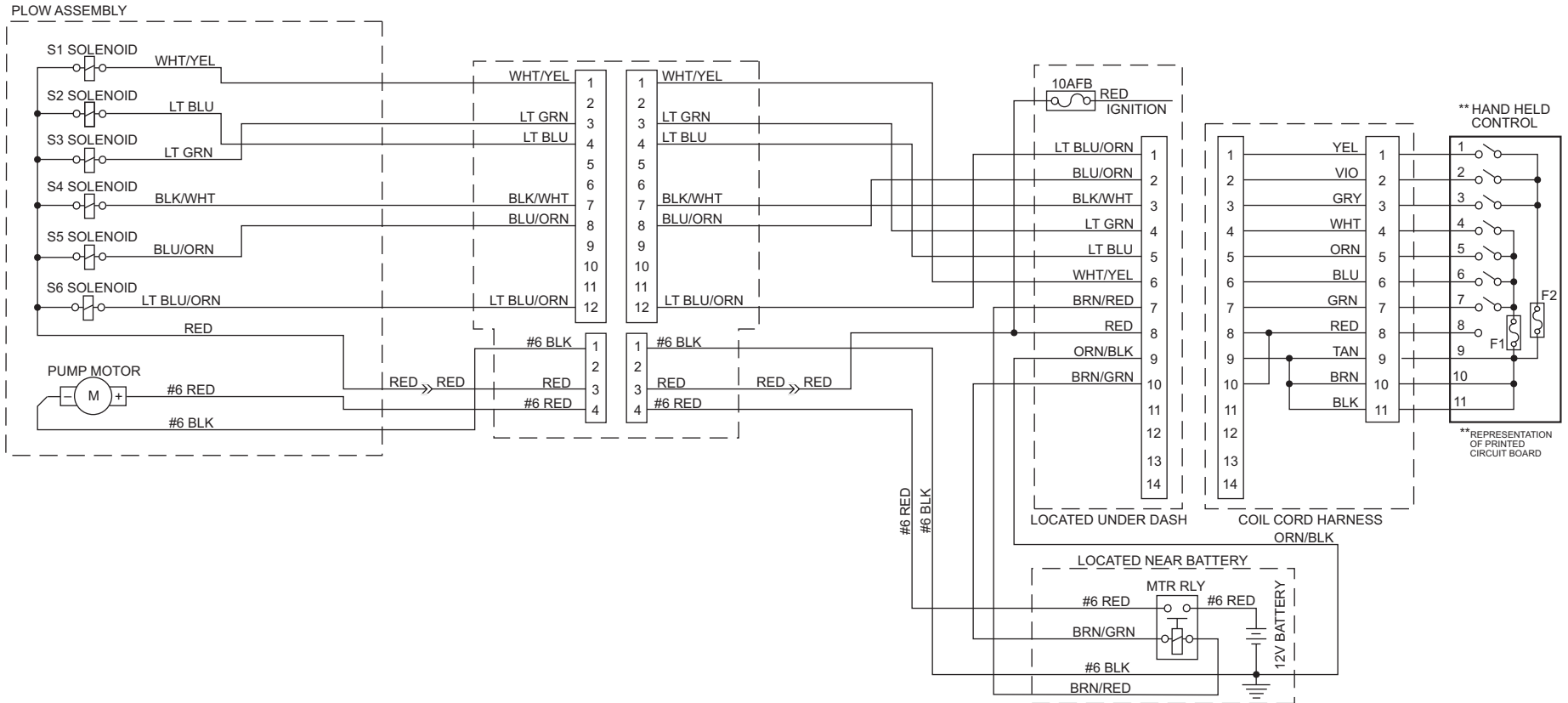

WIRING DIAGRAM – 61185 PARK OR TURN HARNESS KIT



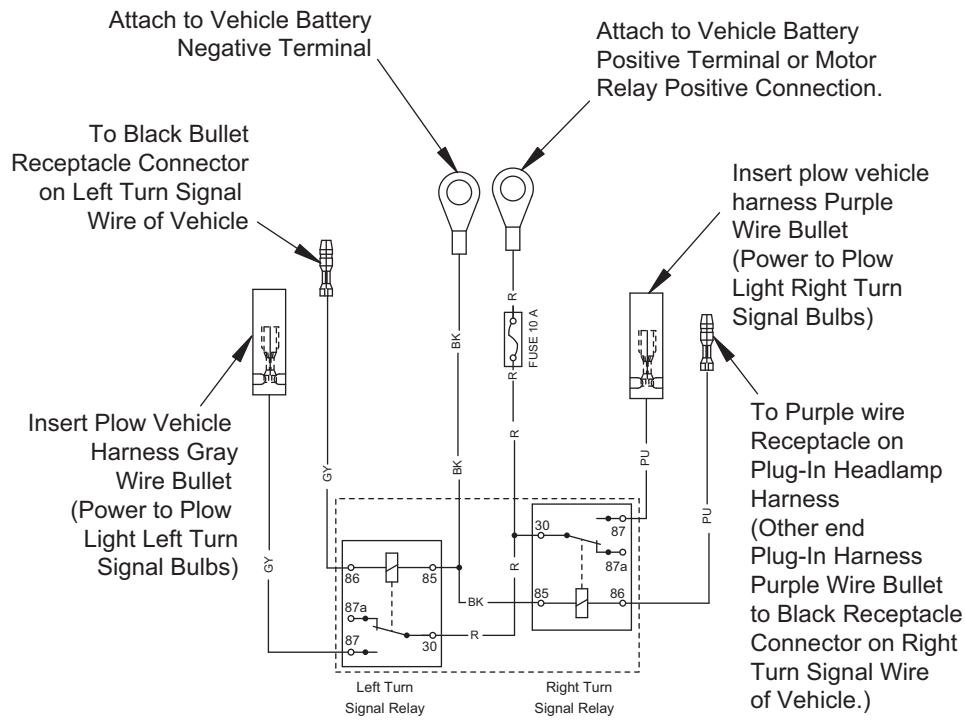



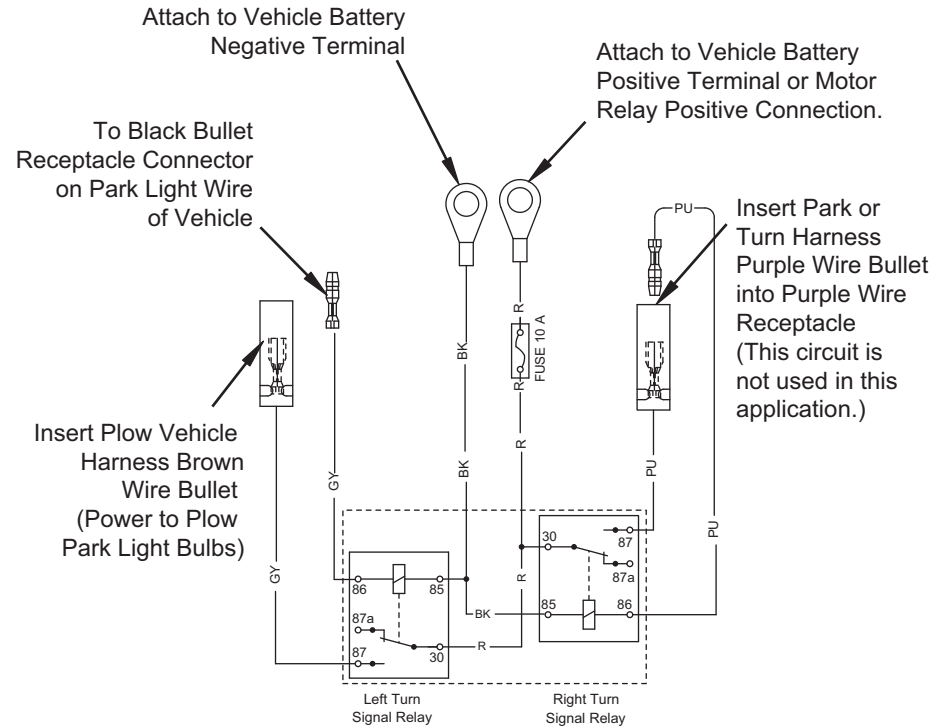



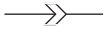

Turn Signal Application



Cab Marker / Park Lamps Application

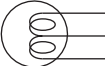
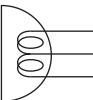

ELECTRICAL LEGEND AND WIRE COLORS

Electrical Legend	
	CROSSING WIRE
	WIRE SPLICE
	IN LINE CONNECTOR
	RING TERMINAL
	FUSE
	SOLENOID { S1 = SV08-2004 S2 = SV08-30 S3 = SV08-40
	DIODE
	CIRCUIT GROUND
	MOTOR RELAY
	BATTERY
	MOTOR
	PARK/TURN LAMP
	HEADLAMP
	COMPONENT ENCLOSURE

Wire Color Code			
BLK	Black	LTBLU	Light Blue
BLK/ORN	Black w/Orange	LTBLU/ORN	Light Blue w/Orange
BLK/RED	Black w/Red	LTBLU/WHT	Light Blue w/White
BLK/WHT	Black w/White	LTGRN	Light Green
BLU	Blue	ORN	Orange
BLU/ORN	Blue w/Orange	ORN/BLK	Orange w/Black
BRN	Brown	PNK	Pink
BRN/RED	Brown w/Red	PUR	Purple
DKBLU	Dark Blue	RED	Red
DKBLU/ORN	Dark Blue w/Orange	TAN	Tan
DKBLU/WHT	Dark Blue w/White	WHT	White
GRN	Green	WHT/YEL	White w/Yellow
GRN/WHT	Green w/White	YEL	Yellow
GRY	Gray		

90

Abbreviations			
DRL	Daytime Running Lights	MTR RLY	Motor Relay

Harness Type	Description
A	Common Ground to Headlamps
B	GM DRL System
C	Independent Ground to Headlamps
D	GM Enhanced DRL System
E	Not Used
F	Common 12V to Headlamps
G	Headlamp Timer Module
H	Independent Headlamp, Common Ground



Western Products
PO Box 245038
Milwaukee, WI 53224-9538
www.westernplows.com

 A DIVISION OF DOUGLAS DYNAMICS, L.L.C.

Copyright © 2008 Douglas Dynamics, L.L.C. All rights reserved. This material may not be reproduced or copied, in whole or in part, in any printed, mechanical, electronic, film or other distribution and storage media, without the written consent of Western Products. Authorization to photocopy items for internal or personal use by Western Products outlets or snowplow owner is granted.

Western Products reserves the right under its product improvement policy to change construction or design details and furnish equipment when so altered without reference to illustrations or specifications used. Western Products or the vehicle manufacturer may require or recommend optional equipment for snow removal. Do not exceed vehicle ratings with a snowplow. This product is manufactured under the following U.S. patents: 4,999,935; 5,420,480; 5,638,618; 5,899,007; 6,145,222; 6,209,231; 6,253,470; 6,408,549; 6,526,677; 6,928,757; 6,941,685; RE35,700; CAN patent 2,060,425; 2,184,922; 2,229,783; 2,354,257 and other patents pending. Western Products offers a limited warranty for all snowplows and accessories. See separately printed page for this important information. The following are registered (®) or unregistered (™) trademarks of Douglas Dynamics, L.L.C.: FloStat®, MVP®, MVP PLUS™, PRO-PLOW®, PRO PLUS®, Roll-Action™, UltraMount®, WESTERN®, WIDE-OUT™.

Printed in U.S.A.